

STATE	PROJECT NO.	SHEET NO.	TOTAL SHEETS
N.C.			
WBS NO.	2024CPT.J0.05.J0601 2024CPT.J0.05.20601		

PAVEMENT SCHEDULE	
C1	PROP. APPROX. 1.5" ASPHALT CONCRETE SURFACE COURSE, TYPE S9.5B, AT AN AVERAGE RATE OF 165 LBS. PER SQ. YD.
C2	PROP. APPROX. 1.5" ASPHALT CONCRETE SURFACE COURSE, TYPE S9.5C, AT AN AVERAGE RATE OF 168 LBS. PER SQ. YD.
C3	ASPHALT CONCRETE LEVELING COURSE, TYPE S9.5B, PLACED AT A VARIABLE RATE AS DIRECTED BY THE ENGINEER.
T	SHOULDER RECONSTRUCTION
U	EXISTING PAVEMENT
V1	MILLING 1.5" DEPTH
V2	PROFILE MILLING 0" TO 1.5"
V3	INCIDENTAL MILLING
Z	MILLED RUMBLE STRIPS

OLD STATESVILLE RD.

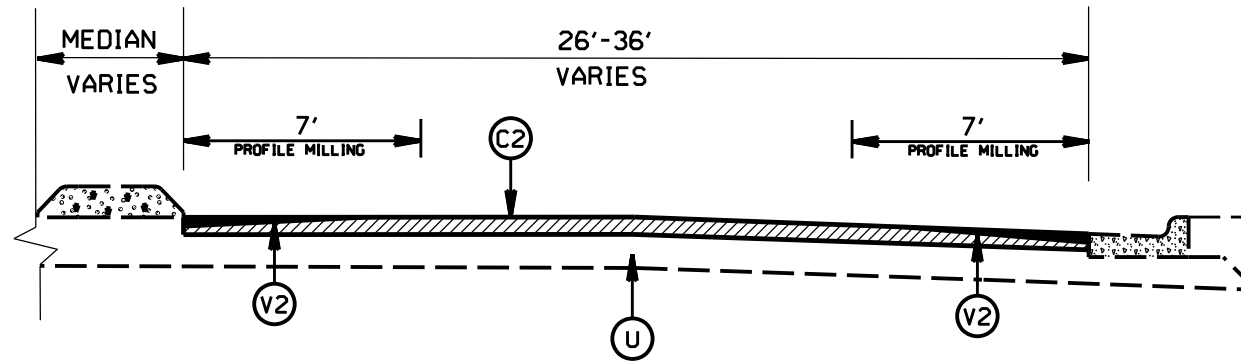

TYPICAL SECTION NO. 1

OLD STATESVILLE RD

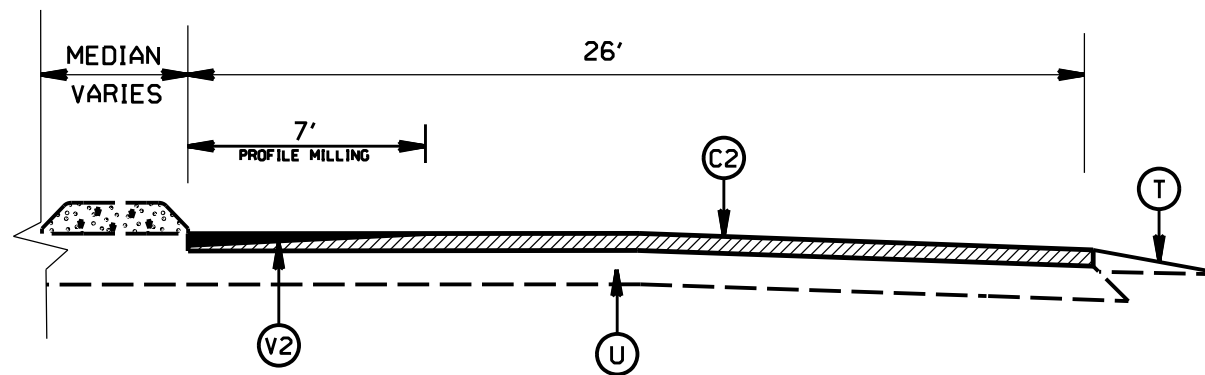

TYPICAL SECTION NO. 2

PATCHING DETAIL

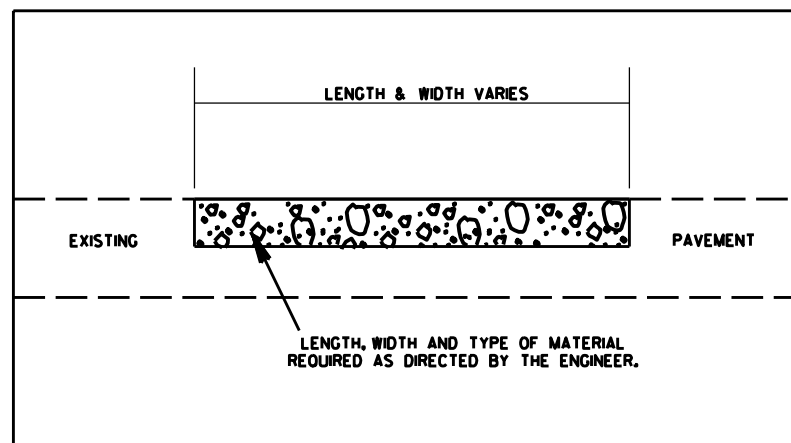

2024 MECKLENBURG COUNTY
RESURFACING CONTRACT 1

SCALE	-NA-		REVISIONS
DATE	7/23		
DWG. BY	JHE		
DESIGN BY	JHE		
APPROVED			

STATE	PROJECT NO.	SHEET NO.	TOTAL SHEETS
N.C.			
WBS NO.	2024CPT.J0.05.J0601 2024CPT.J0.05.20601		

PAVEMENT SCHEDULE	
C1	PROP. APPROX. 1.5" ASPHALT CONCRETE SURFACE COURSE, TYPE S9.5B, AT AN AVERAGE RATE OF 165 LBS. PER SQ. YD.
C2	PROP. APPROX. 1.5" ASPHALT CONCRETE SURFACE COURSE, TYPE S9.5C, AT AN AVERAGE RATE OF 168 LBS. PER SQ. YD.
C3	ASPHALT CONCRETE LEVELING COURSE, TYPE S9.5B, PLACED AT A VARIABLE RATE AS DIRECTED BY THE ENGINEER.
T	SHOULDER RECONSTRUCTION
U	EXISTING PAVEMENT
V1	MILLING 1.5" DEPTH
V2	PROFILE MILLING 0" TO 1.5"
V3	INCIDENTAL MILLING
Z	MILLED RUMBLE STRIPS

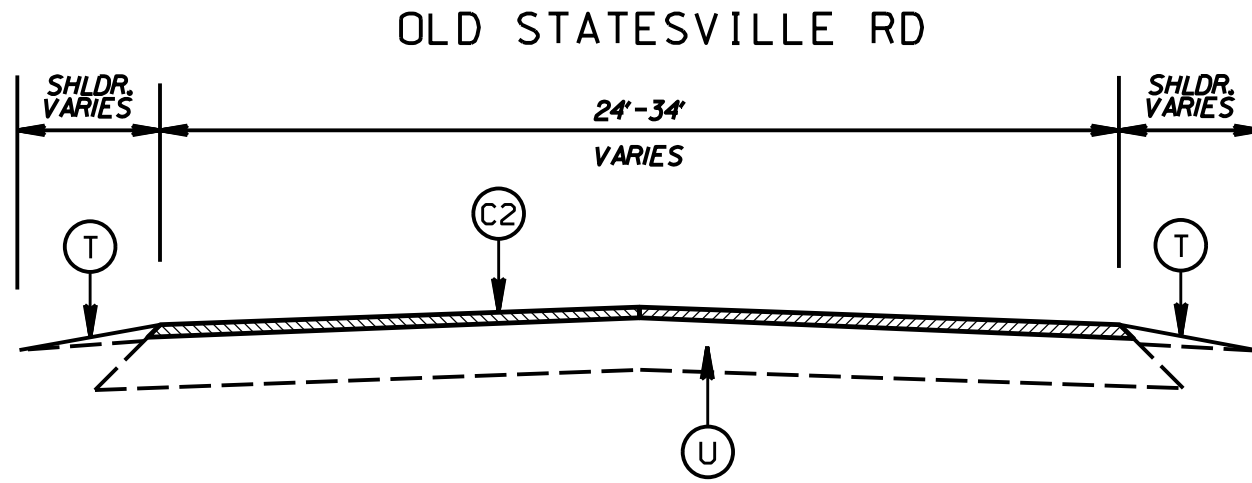

TYPICAL SECTION NO. 3

OLD STATESVILLE RD.

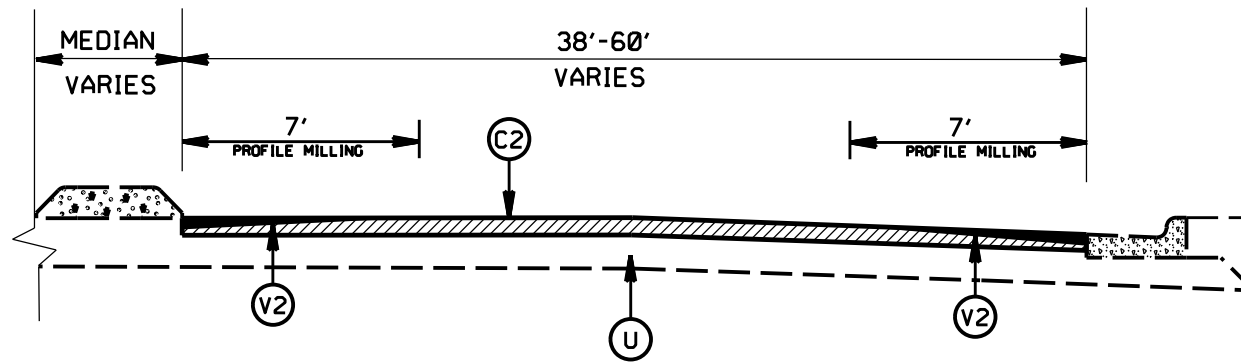

TYPICAL SECTION NO. 4

PATCHING DETAIL

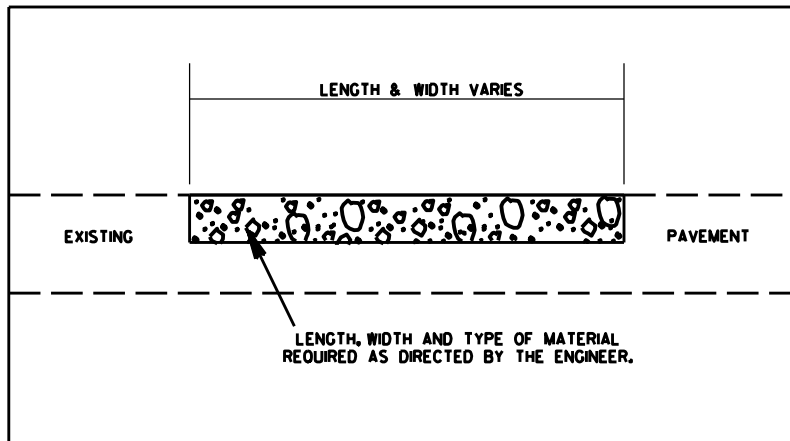

2024 MECKLENBURG COUNTY
RESURFACING CONTRACT 1

SCALE	-NA-
DATE	7/23
DWG. BY	JHE
DESIGN BY	JHE
APPROVED	



REVISIONS	

STATE	PROJECT NO.	SHEET NO.	TOTAL SHEETS
N.C.			
WBS NO.	2024CPT_0.05.0601 2024CPT_0.05.20601		

PAVEMENT SCHEDULE	
C1	PROP. APPROX. 1.5" ASPHALT CONCRETE SURFACE COURSE, TYPE S9.5B, AT AN AVERAGE RATE OF 165 LBS. PER SQ. YD.
C2	PROP. APPROX. 1.5" ASPHALT CONCRETE SURFACE COURSE, TYPE S9.5C, AT AN AVERAGE RATE OF 168 LBS. PER SQ. YD.
C3	ASPHALT CONCRETE LEVELING COURSE, TYPE S9.5B, PLACED AT A VARIABLE RATE AS DIRECTED BY THE ENGINEER.
T	SHOULDER RECONSTRUCTION
U	EXISTING PAVEMENT
V1	MILLING 1.5" DEPTH
V2	PROFILE MILLING 0" TO 1.5"
V3	INCIDENTAL MILLING
Z	MILLED RUMBLE STRIPS

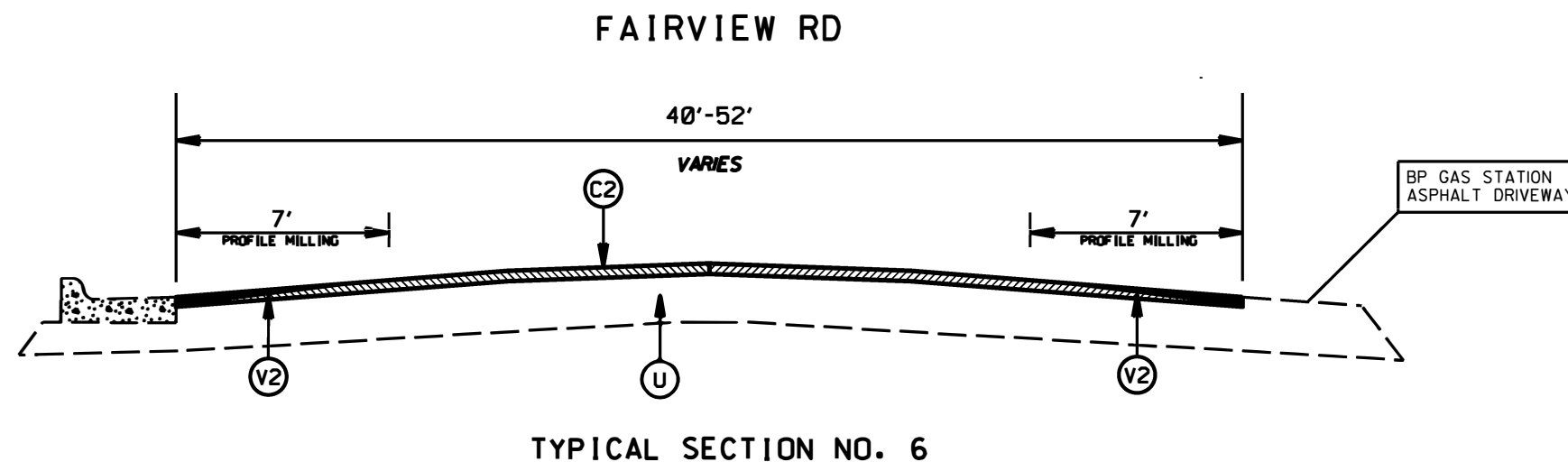
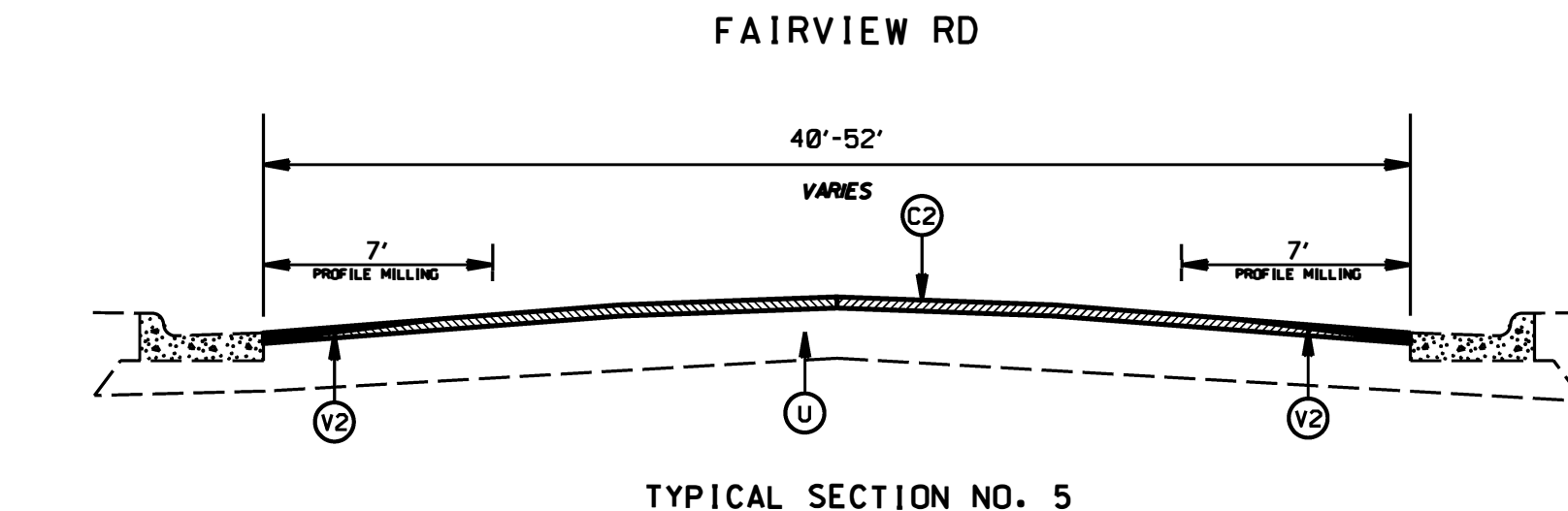

PATCHING DETAIL

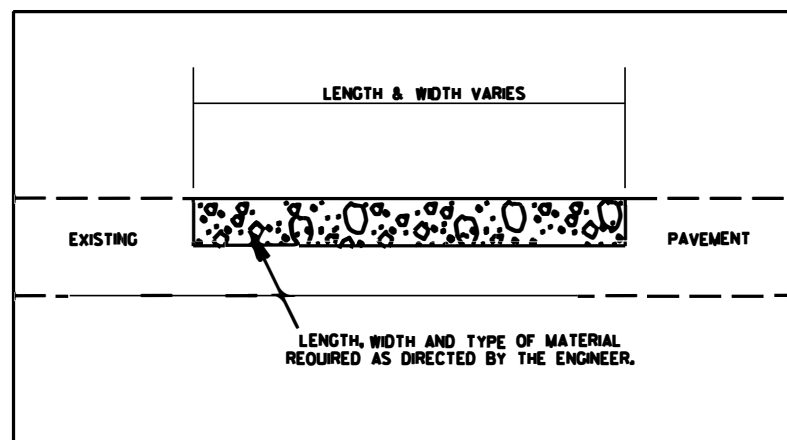

**2024 MECKLENBURG COUNTY
RESURFACING CONTRACT 1**

SCALE	-NA-		REVISIONS
DATE	7/23		
DWG. BY	JHE		
DESIGN BY	JHE		
APPROVED			

STATE	PROJECT NO.	SHEET NO.	TOTAL SHEETS
N.C.			
WBS NO.	2024CPT.J0.05.J0601		
	2024CPT.J0.05.20601		

PAVEMENT SCHEDULE	
C1	PROP. APPROX. 1.5" ASPHALT CONCRETE SURFACE COURSE, TYPE S9.5B, AT AN AVERAGE RATE OF 165 LBS. PER SQ. YD.
C2	PROP. APPROX. 1.5" ASPHALT CONCRETE SURFACE COURSE, TYPE S9.5C, AT AN AVERAGE RATE OF 168 LBS. PER SQ. YD.
C3	ASPHALT CONCRETE LEVELING COURSE, TYPE S9.5B, PLACED AT A VARIABLE RATE AS DIRECTED BY THE ENGINEER.
T	SHOULDER RECONSTRUCTION
U	EXISTING PAVEMENT
V1	MILLING 1.5" DEPTH
V2	PROFILE MILLING 0" TO 1.5"
V3	INCIDENTAL MILLING
Z	MILLED RUMBLE STRIPS

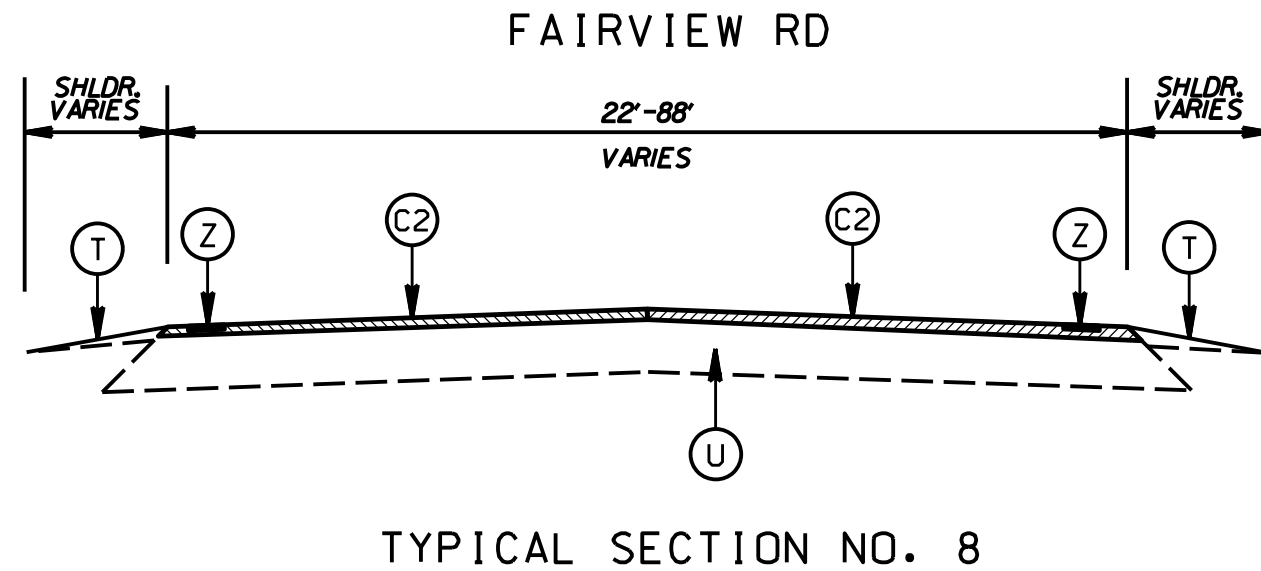
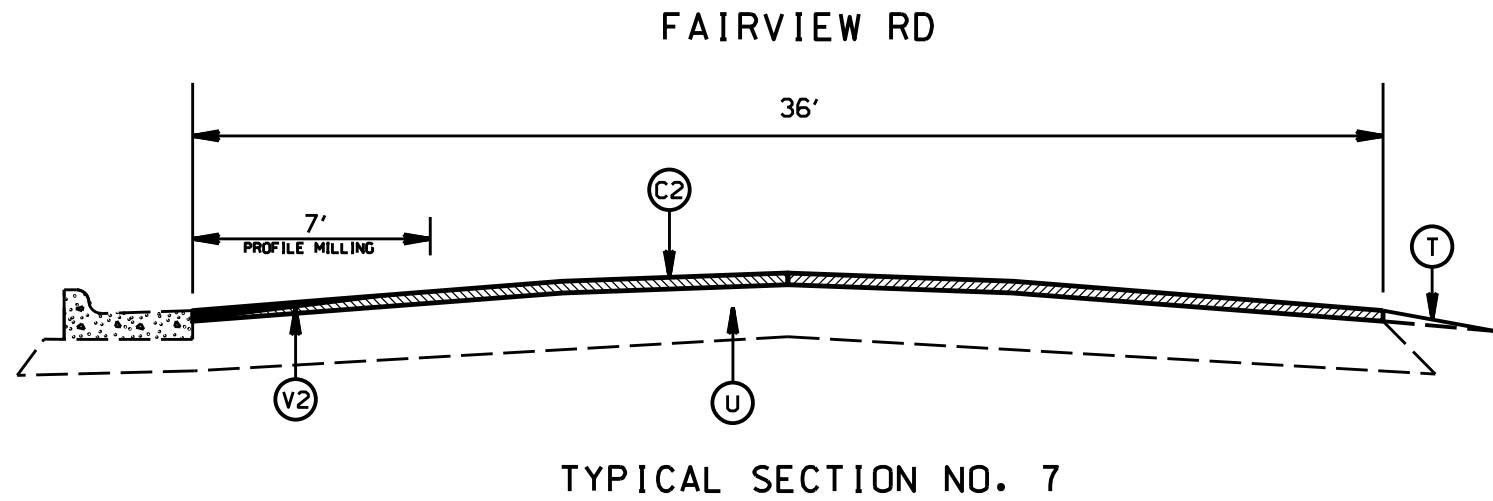

PATCHING DETAIL

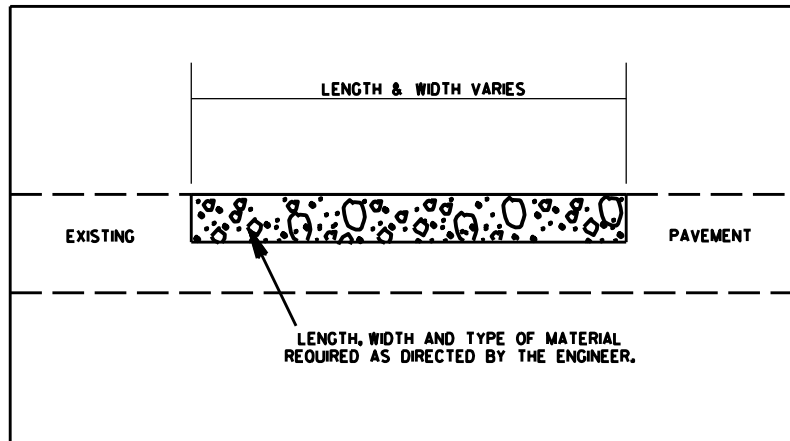

2024 MECKLENBURG COUNTY
RESURFACING CONTRACT 1

SCALE	-NA-		REVISIONS
DATE	7/23		
DWG. BY	JHE		
DESIGN BY	JHE		
APPROVED			

STATE	PROJECT NO.	SHEET NO.	TOTAL SHEETS
N.C.			
WBS NO.	2024CPT.I0.05.I060I 2024CPT.I0.05.2060I		

PAVEMENT SCHEDULE	
C1	PROP. APPROX. 1.5" ASPHALT CONCRETE SURFACE COURSE, TYPE S9.5B, AT AN AVERAGE RATE OF 165 LBS. PER SQ. YD.
C2	PROP. APPROX. 1.5" ASPHALT CONCRETE SURFACE COURSE, TYPE S9.5C, AT AN AVERAGE RATE OF 168 LBS. PER SQ. YD.
C3	ASPHALT CONCRETE LEVELING COURSE, TYPE S9.5B, PLACED AT A VARIABLE RATE AS DIRECTED BY THE ENGINEER.
T	SHOULDER RECONSTRUCTION
U	EXISTING PAVEMENT
V1	MILLING 1.5" DEPTH
V2	PROFILE MILLING 0" TO 1.5"
V3	INCIDENTAL MILLING
Z	MILLED RUMBLE STRIPS

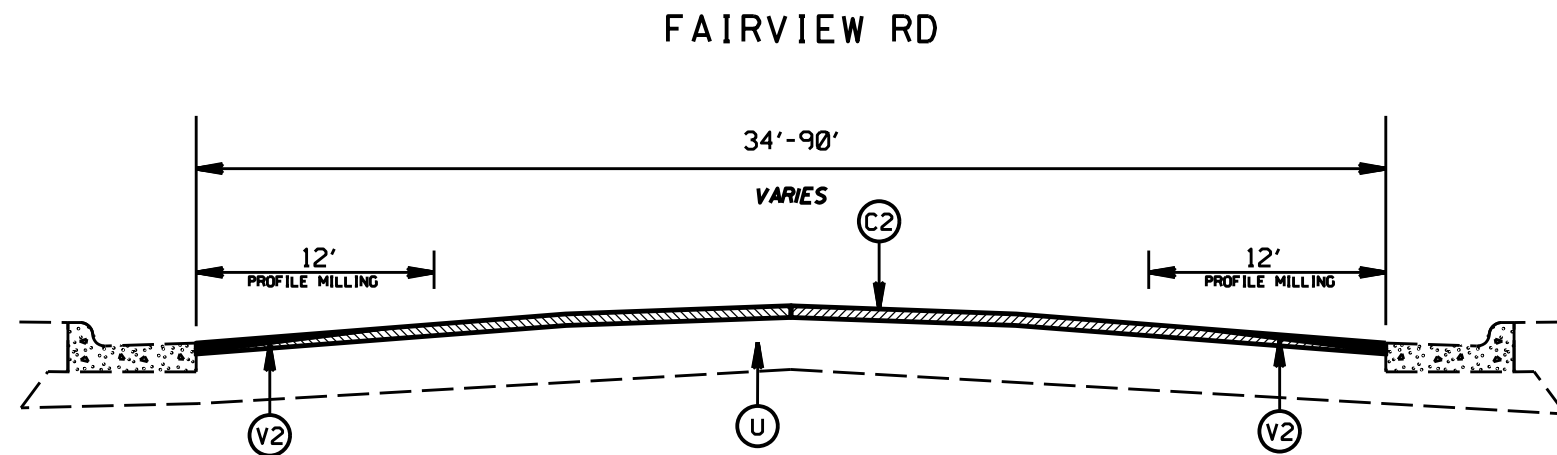

TYPICAL SECTION NO. 9

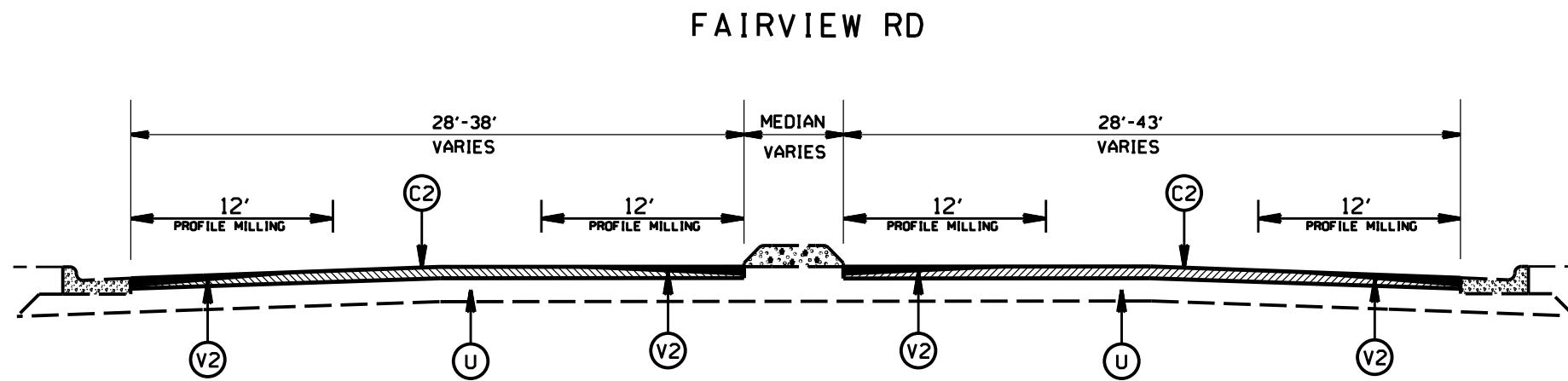

TYPICAL SECTION NO. 10

PATCHING DETAIL

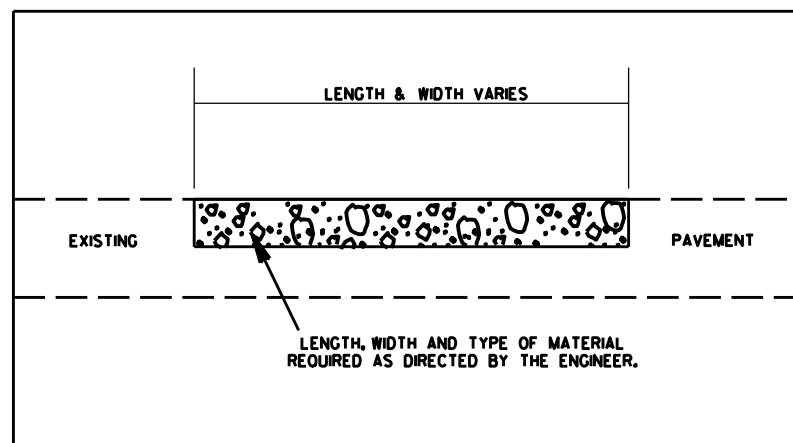

2024 MECKLENBURG COUNTY
RESURFACING CONTRACT 1

SCALE	-NA-		REVISIONS
DATE	7/23		
DWG. BY	JHE		
DESIGN BY	JHE		
APPROVED			

STATE	PROJECT NO.	SHEET NO.	TOTAL SHEETS
N.C.			
WBS NO.	2024CPT.J0.05.J0601 2024CPT.J0.05.20601		

PAVEMENT SCHEDULE

C1	PROP. APPROX. 1.5" ASPHALT CONCRETE SURFACE COURSE, TYPE S9.5B, AT AN AVERAGE RATE OF 165 LBS. PER SQ. YD.
C2	PROP. APPROX. 1.5" ASPHALT CONCRETE SURFACE COURSE, TYPE S9.5C, AT AN AVERAGE RATE OF 168 LBS. PER SQ. YD.
C3	ASPHALT CONCRETE LEVELING COURSE, TYPE S9.5B, PLACED AT A VARIABLE RATE AS DIRECTED BY THE ENGINEER.
T	SHOULDER RECONSTRUCTION
U	EXISTING PAVEMENT
V1	MILLING 1.5" DEPTH
V2	PROFILE MILLING 0" TO 1.5"
V3	INCIDENTAL MILLING
Z	MILLED RUMBLE STRIPS

JOSH BIRMINGHAM PKWY RAMP

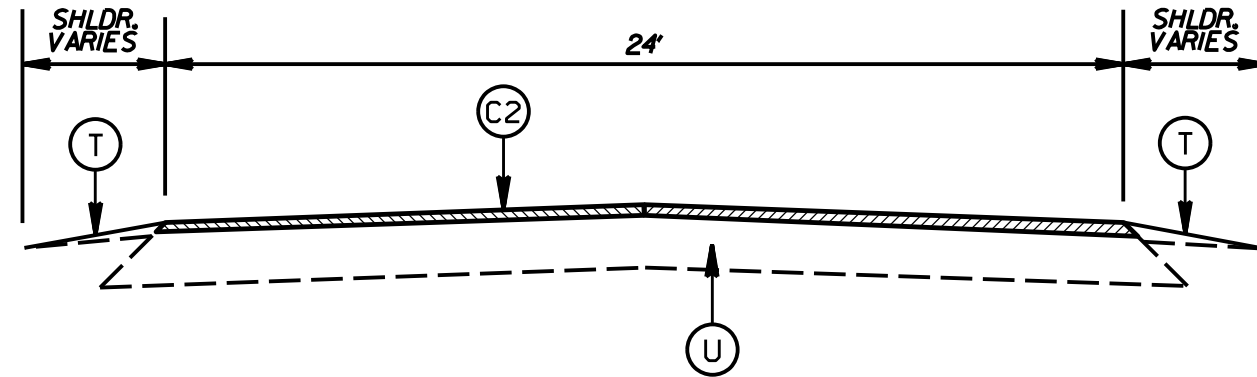

TYPICAL SECTION NO. 11

JOSH BIRMINGHAM PKWY RAMP

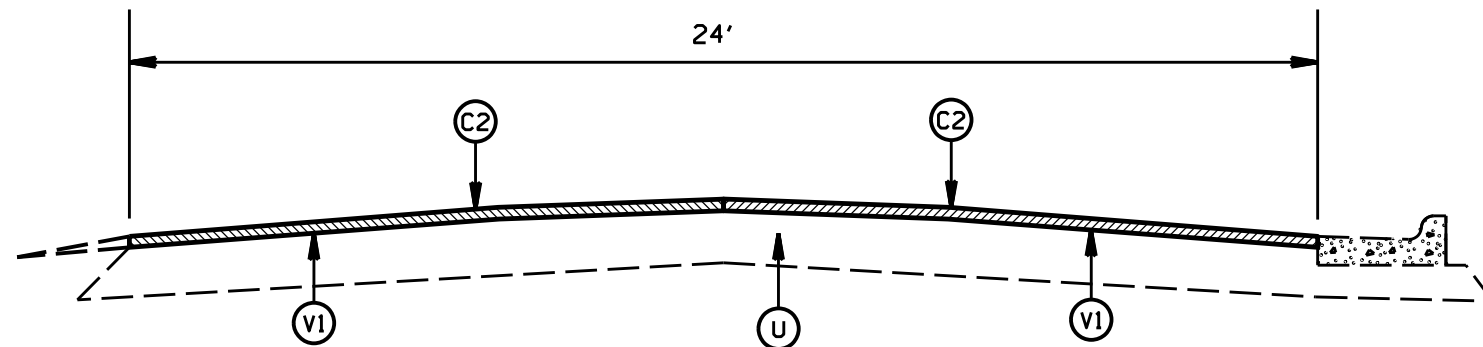

TYPICAL SECTION NO. 12

PATCHING DETAIL

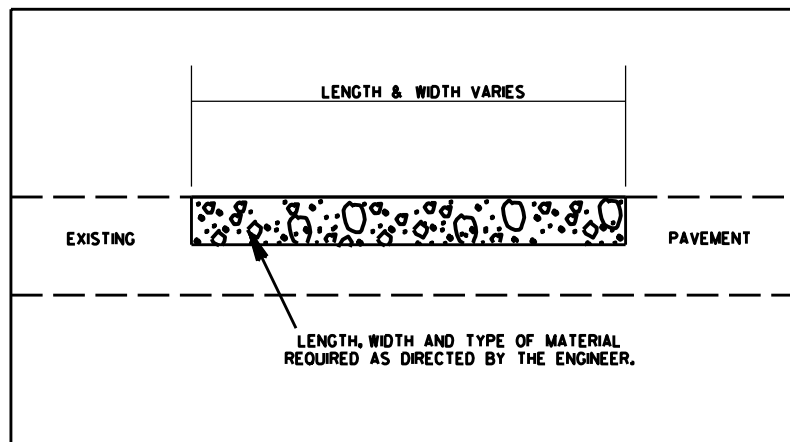

2024 MECKLENBURG COUNTY
RESURFACING CONTRACT 1

SCALE	-NA-
DATE	7/23
DWG. BY	JHE
DESIGN BY	JHE
APPROVED	



REVISIONS	

STATE	PROJECT NO.	SHEET NO.	TOTAL SHEETS
N.C.			
WBS NO.	2024CPT.I0.05.I060I 2024CPT.I0.05.2060I		

PAVEMENT SCHEDULE	
C1	PROP. APPROX. 1.5" ASPHALT CONCRETE SURFACE COURSE, TYPE S9.5B, AT AN AVERAGE RATE OF 165 LBS. PER SQ. YD.
C2	PROP. APPROX. 1.5" ASPHALT CONCRETE SURFACE COURSE, TYPE S9.5C, AT AN AVERAGE RATE OF 168 LBS. PER SQ. YD.
C3	ASPHALT CONCRETE LEVELING COURSE, TYPE S9.5B, PLACED AT A VARIABLE RATE AS DIRECTED BY THE ENGINEER.
T	SHOULDER RECONSTRUCTION
U	EXISTING PAVEMENT
V1	MILLING 1.5" DEPTH
V2	PROFILE MILLING 0" TO 1.5"
V3	INCIDENTAL MILLING
Z	MILLED RUMBLE STRIPS

JOSH BIRMINGHAM PKWY RAMP

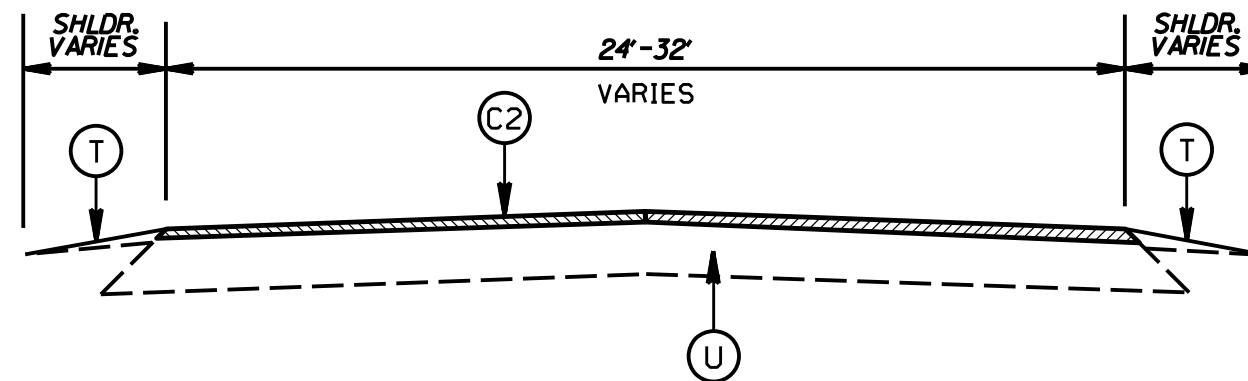

TYPICAL SECTION NO. 13

WEDDINGTON ROAD

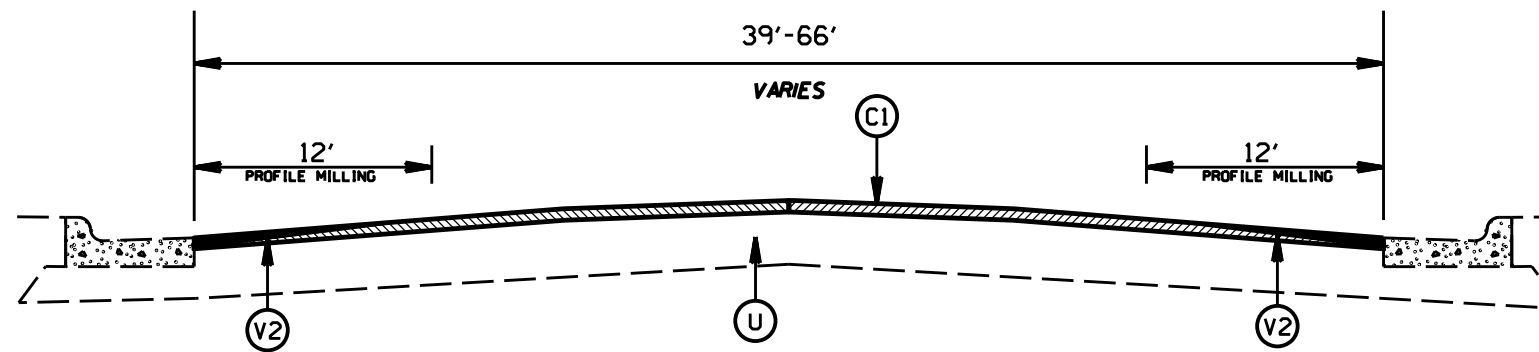

TYPICAL SECTION NO. 14

PATCHING DETAIL

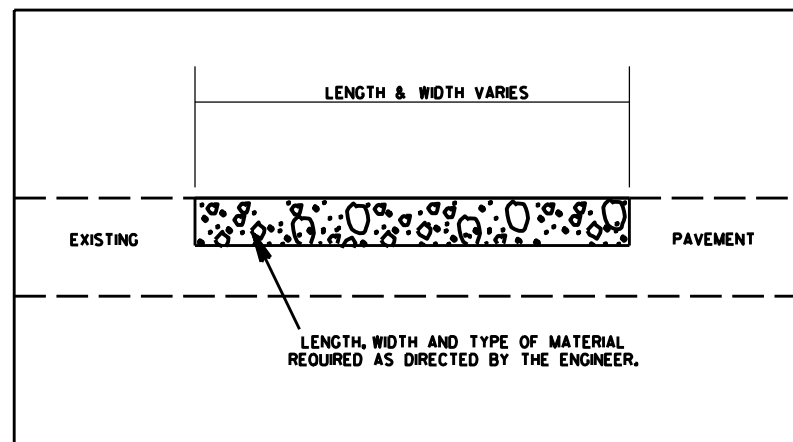

2024 MECKLENBURG COUNTY
RESURFACING CONTRACT 1

SCALE	-NA-
DATE	7/23
DWG. BY	JHE
DESIGN BY	JHE
APPROVED	



REVISIONS	

STATE	PROJECT NO.	SHEET NO.	TOTAL SHEETS
N.C.			
WBS NO.	2024CPT.J0.05.J0601 2024CPT.J0.05.20601		

PAVEMENT SCHEDULE	
C1	PROP. APPROX. 1.5" ASPHALT CONCRETE SURFACE COURSE, TYPE S9.5B, AT AN AVERAGE RATE OF 165 LBS. PER SQ. YD.
C2	PROP. APPROX. 1.5" ASPHALT CONCRETE SURFACE COURSE, TYPE S9.5C, AT AN AVERAGE RATE OF 168 LBS. PER SQ. YD.
C3	ASPHALT CONCRETE LEVELING COURSE, TYPE S9.5B, PLACED AT A VARIABLE RATE AS DIRECTED BY THE ENGINEER.
T	SHOULDER RECONSTRUCTION
U	EXISTING PAVEMENT
V1	MILLING 1.5" DEPTH
V2	PROFILE MILLING 0" TO 1.5"
V3	INCIDENTAL MILLING
Z	MILLED RUMBLE STRIPS

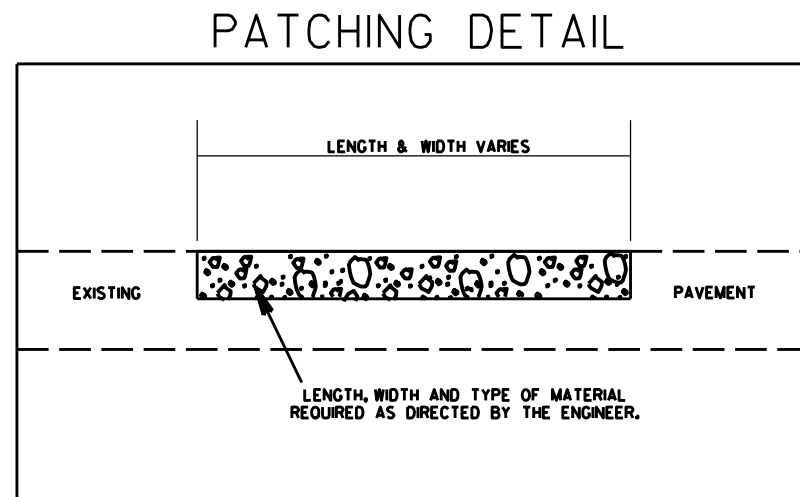
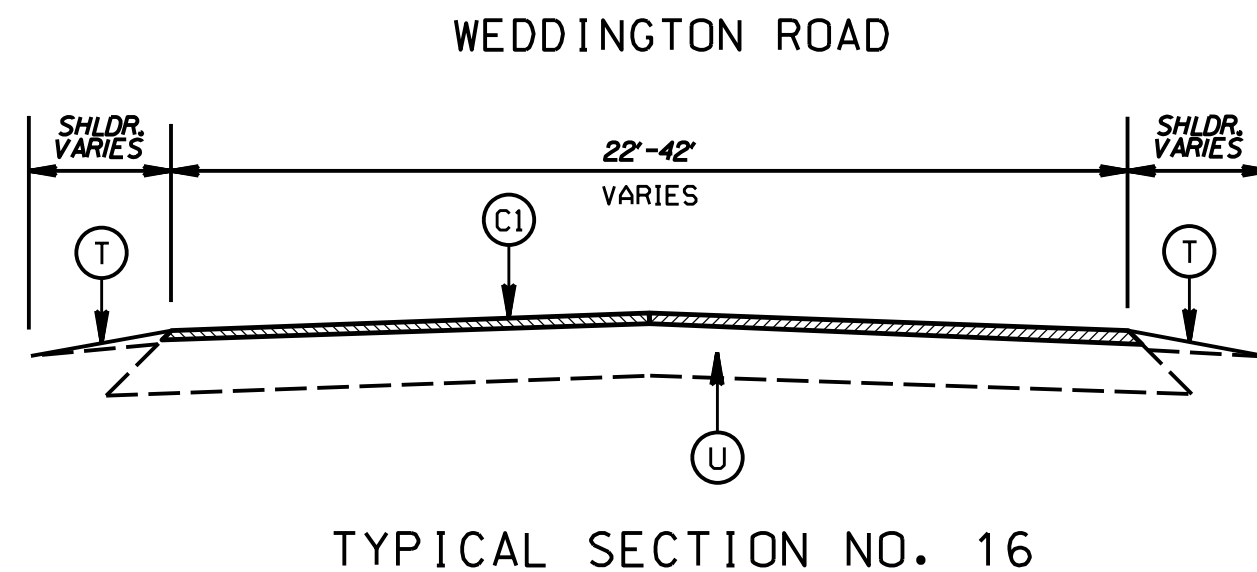
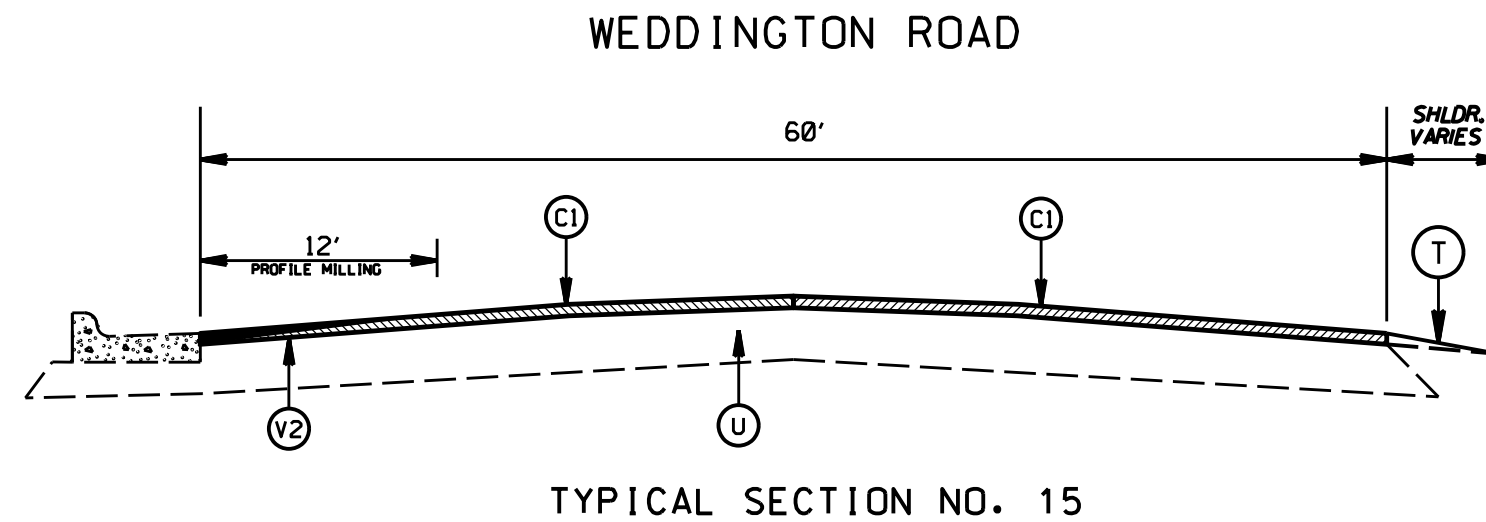

2024 MECKLENBURG COUNTY
RESURFACING CONTRACT 1

SCALE	-NA-		REVISIONS
DATE	7/23		
DWG. BY	JHE		
DESIGN BY	JHE		
APPROVED			

STATE	PROJECT NO.	SHEET NO.	TOTAL SHEETS
N.C.			
WBS NO.	2024CPT,JO.05.J0601 2024CPT,JO.05.20601		

PAVEMENT SCHEDULE	
C1	PROP. APPROX. 1.5" ASPHALT CONCRETE SURFACE COURSE, TYPE S9.5B, AT AN AVERAGE RATE OF 165 LBS. PER SQ. YD.
C2	PROP. APPROX. 1.5" ASPHALT CONCRETE SURFACE COURSE, TYPE S9.5C, AT AN AVERAGE RATE OF 168 LBS. PER SQ. YD.
C3	ASPHALT CONCRETE LEVELING COURSE, TYPE S9.5B, PLACED AT A VARIABLE RATE AS DIRECTED BY THE ENGINEER.
T	SHOULDER RECONSTRUCTION
U	EXISTING PAVEMENT
V1	MILLING 1.5" DEPTH
V2	PROFILE MILLING 0" TO 1.5"
V3	INCIDENTAL MILLING
Z	MILLED RUMBLE STRIPS

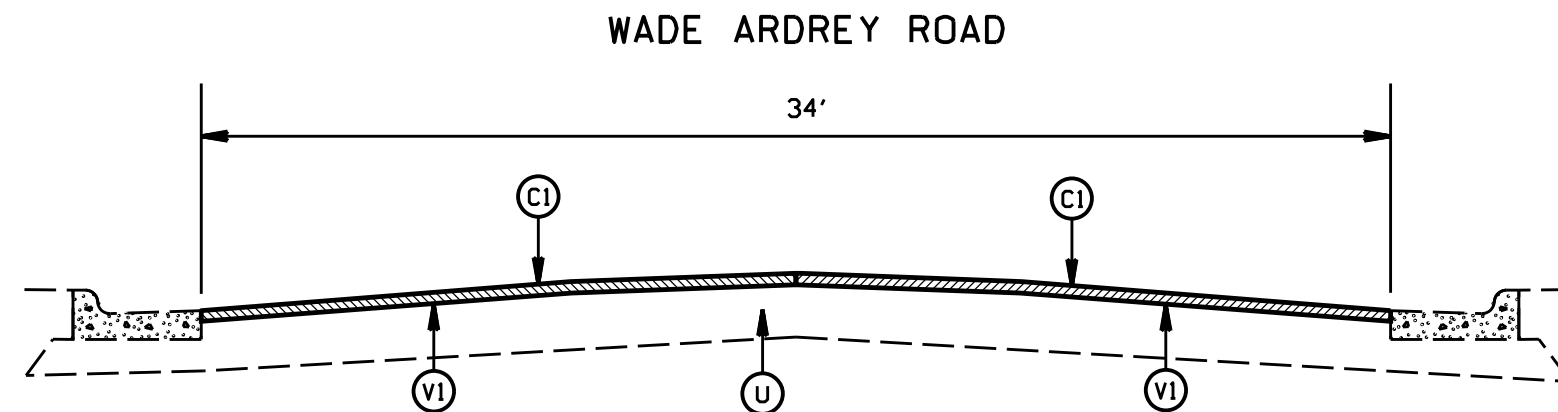

TYPICAL SECTION NO. 17

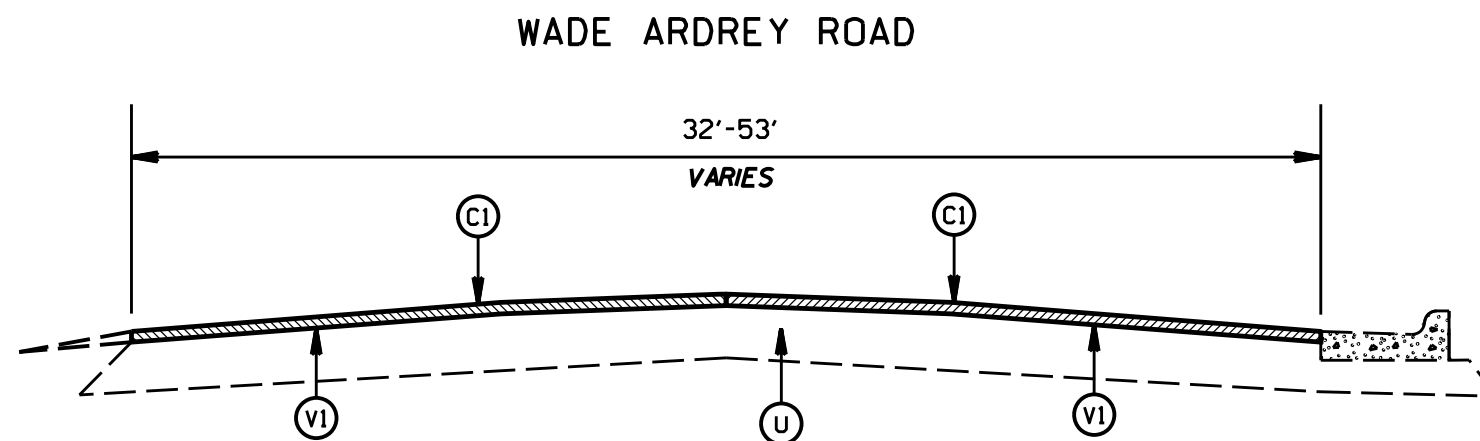

TYPICAL SECTION NO. 18

PATCHING DETAIL

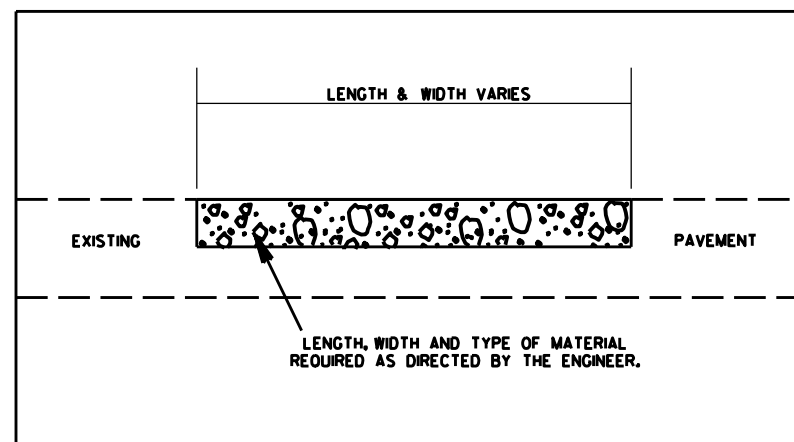

2024 MECKLENBURG COUNTY
RESURFACING CONTRACT 1

SCALE	-NA-
DATE	7/23
DWG. BY	JHE
DESIGN BY	JHE
APPROVED	



REVISIONS	

STATE	PROJECT NO.	SHEET NO.	TOTAL SHEETS
N.C.			
WBS NO.	2024CPT.10.05.10601 2024CPT.10.05.20601		

PAVEMENT SCHEDULE	
C1	PROP. APPROX. 1.5" ASPHALT CONCRETE SURFACE COURSE, TYPE S9.5B, AT AN AVERAGE RATE OF 165 LBS. PER SQ. YD.
C2	PROP. APPROX. 1.5" ASPHALT CONCRETE SURFACE COURSE, TYPE S9.5C, AT AN AVERAGE RATE OF 168 LBS. PER SQ. YD.
C3	ASPHALT CONCRETE LEVELING COURSE, TYPE S9.5B, PLACED AT A VARIABLE RATE AS DIRECTED BY THE ENGINEER.
T	SHOULDER RECONSTRUCTION
U	EXISTING PAVEMENT
V1	MILLING 1.5" DEPTH
V2	PROFILE MILLING 0" TO 1.5"
V3	INCIDENTAL MILLING
Z	MILLED RUMBLE STRIPS

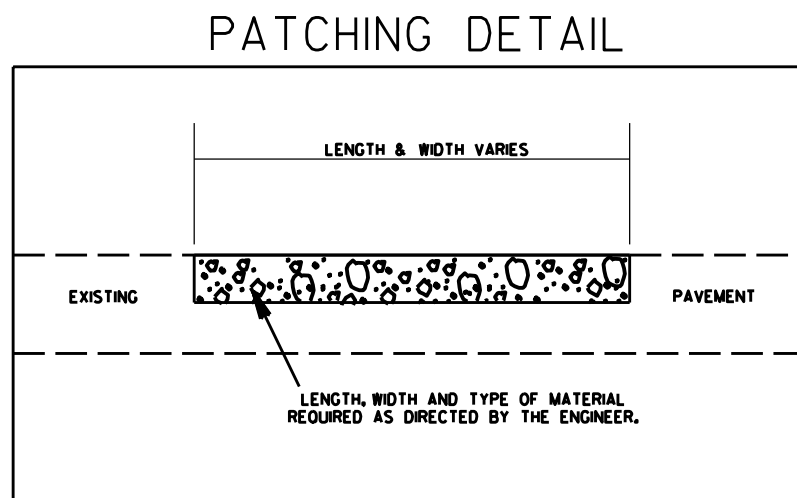
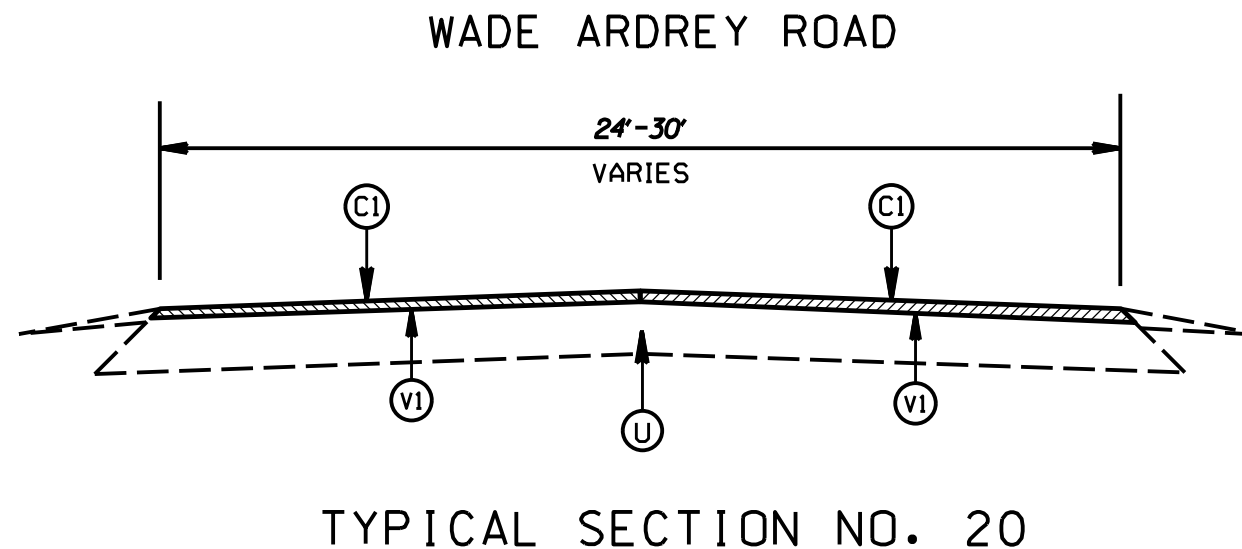
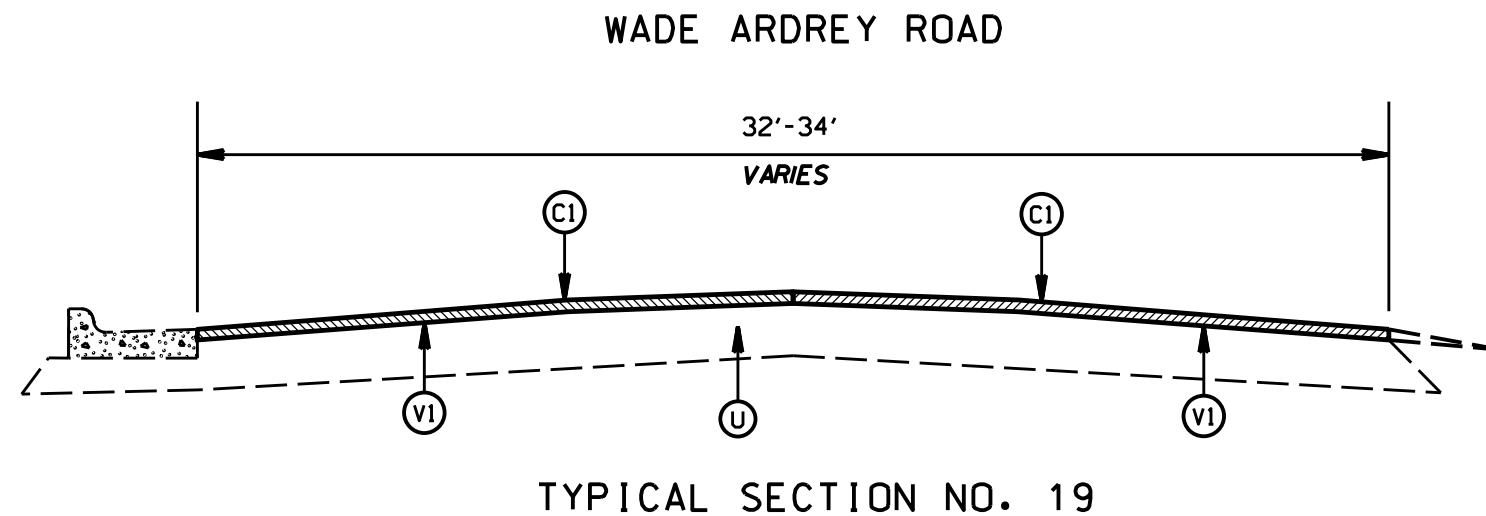

2024 MECKLENBURG COUNTY
RESURFACING CONTRACT 1

SCALE	-NA-		REVISIONS
DATE	7/23		
DWG. BY	JHE		
DESIGN BY	JHE		
APPROVED			

STATE	PROJECT NO.	SHEET NO.	TOTAL SHEETS
N.C.			
WBS NO.	2024CPT.J0.05.J0601 2024CPT.J0.05.20601		

PAVEMENT SCHEDULE	
C1	PROP. APPROX. 1.5" ASPHALT CONCRETE SURFACE COURSE, TYPE S9.5B, AT AN AVERAGE RATE OF 165 LBS. PER SQ. YD.
C2	PROP. APPROX. 1.5" ASPHALT CONCRETE SURFACE COURSE, TYPE S9.5C, AT AN AVERAGE RATE OF 168 LBS. PER SQ. YD.
C3	ASPHALT CONCRETE LEVELING COURSE, TYPE S9.5B, PLACED AT A VARIABLE RATE AS DIRECTED BY THE ENGINEER.
T	SHOULDER RECONSTRUCTION
U	EXISTING PAVEMENT
V1	MILLING 1.5" DEPTH
V2	PROFILE MILLING 0" TO 1.5"
V3	INCIDENTAL MILLING
Z	MILLED RUMBLE STRIPS

INCIDENTAL MILLING

NOTES TO CONTRACTOR:

For surface mixes over 1" in thickness mill the existing pavement in accordance with the following sketch as directed by the engineer.

Locations shall include ties into existing concrete pavement at bridge approaches where the bridge will not be resurfaced, and at the beginning and end point of each resurfacing map.

Perform the work in accordance with section 607 of the January 2018 North Carolina Department of Transportation Standard Specifications for Roads and Structures. Resurfacing will be accomplished at the same time as the milling operation.

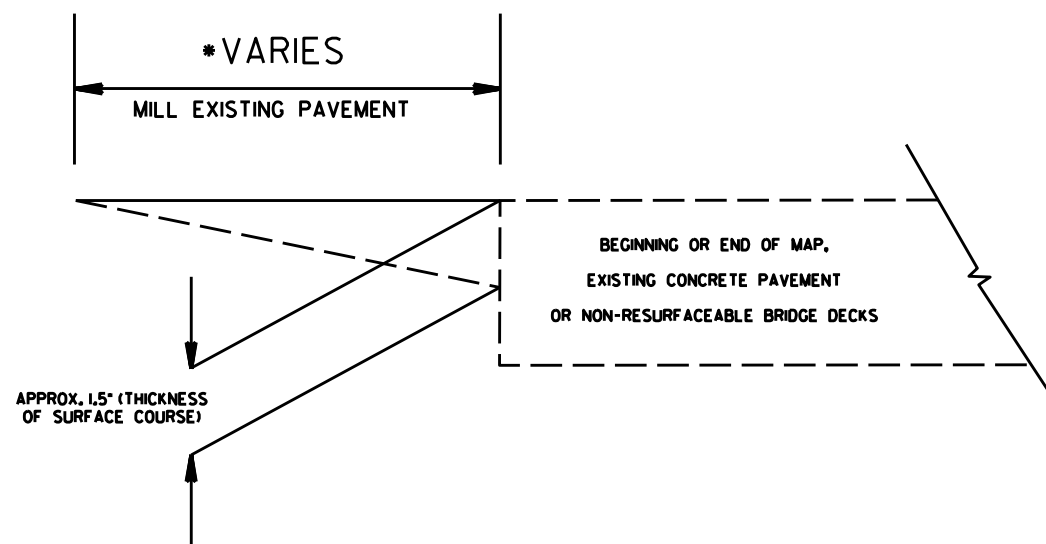

PATCHING DETAIL

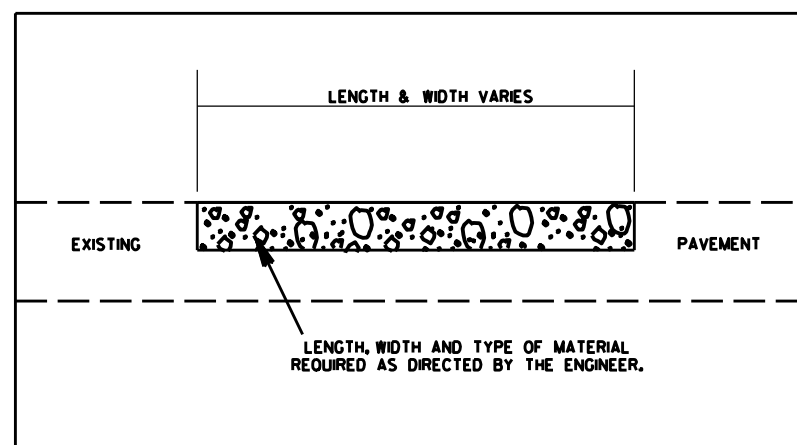

2024 MECKLENBURG COUNTY
RESURFACING CONTRACT 1

SCALE	-NA-		REVISIONS
DATE	7/23		
DWG. BY	JHE		
DESIGN BY	JHE		
APPROVED			

STATE	PROJECT NO.	SHEET NO.	TOTAL SHEETS
N.C.			
WBS NO.	2024CPT.J0.05.J0601 2024CPT.J0.05.20601		

PAVEMENT SCHEDULE	
C1	PROP. APPROX. 1.5" ASPHALT CONCRETE SURFACE COURSE, TYPE S9.5B, AT AN AVERAGE RATE OF 165 LBS. PER SQ. YD.
C2	PROP. APPROX. 1.5" ASPHALT CONCRETE SURFACE COURSE, TYPE S9.5C, AT AN AVERAGE RATE OF 168 LBS. PER SQ. YD.
C3	ASPHALT CONCRETE LEVELING COURSE, TYPE S9.5B, PLACED AT A VARIABLE RATE AS DIRECTED BY THE ENGINEER.
T	SHOULDER RECONSTRUCTION
U	EXISTING PAVEMENT
V1	MILLING 1.5" DEPTH
V2	PROFILE MILLING 0" TO 1.5"
V3	INCIDENTAL MILLING
Z	MILLED RUMBLE STRIPS

W. SUGAR CREEK RD

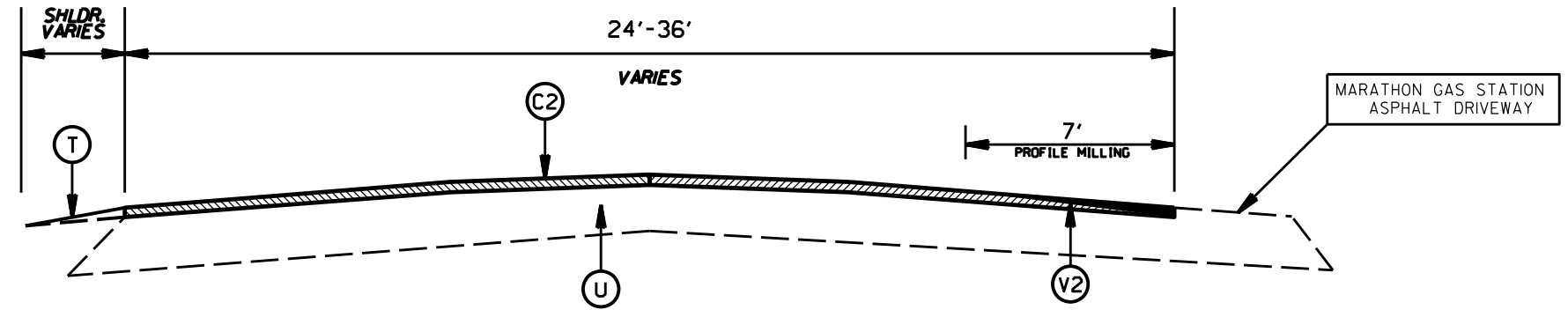

TYPICAL SECTION NO. 21

W. SUGAR CREEK RD

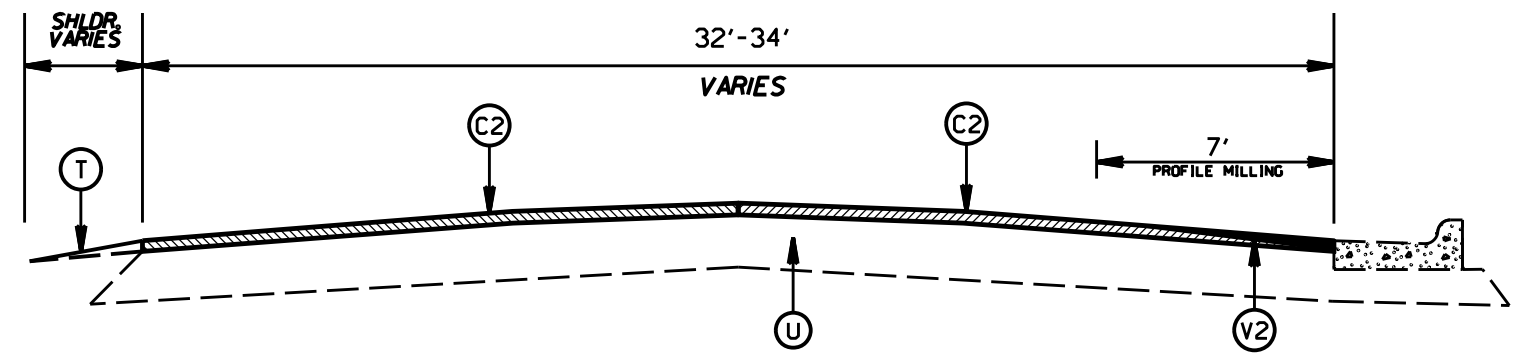

TYPICAL SECTION NO. 22

PATCHING DETAIL

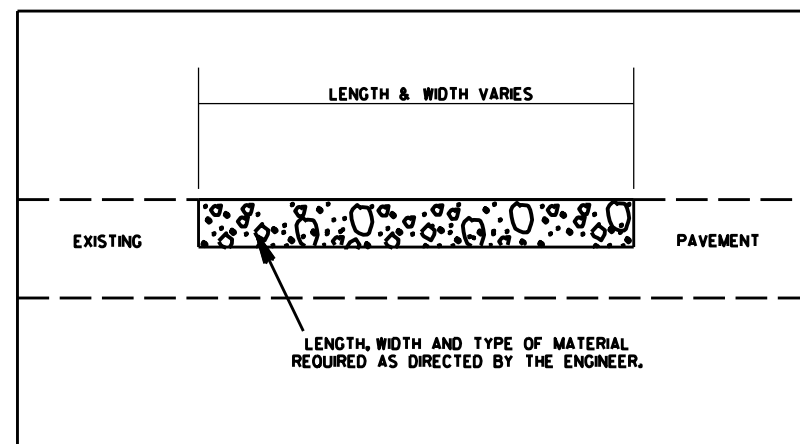

2024 MECKLENBURG COUNTY
RESURFACING CONTRACT 1

SCALE	-NA-		REVISIONS
DATE	7/23		
DWG. BY	JHE		
DESIGN BY	JHE		
APPROVED			

STATE	PROJECT NO.	SHEET NO.	TOTAL SHEETS
N.C.			
WBS NO.	2024CPT.J0.05.J0601 2024CPT.J0.05.20601		

PAVEMENT SCHEDULE	
C1	PROP. APPROX. 1.5" ASPHALT CONCRETE SURFACE COURSE, TYPE S9.5B, AT AN AVERAGE RATE OF 165 LBS. PER SQ. YD.
C2	PROP. APPROX. 1.5" ASPHALT CONCRETE SURFACE COURSE, TYPE S9.5C, AT AN AVERAGE RATE OF 168 LBS. PER SQ. YD.
C3	ASPHALT CONCRETE LEVELING COURSE, TYPE S9.5B, PLACED AT A VARIABLE RATE AS DIRECTED BY THE ENGINEER.
T	SHOULDER RECONSTRUCTION
U	EXISTING PAVEMENT
V1	MILLING 1.5" DEPTH
V2	PROFILE MILLING 0" TO 1.5"
V3	INCIDENTAL MILLING
Z	MILLED RUMBLE STRIPS

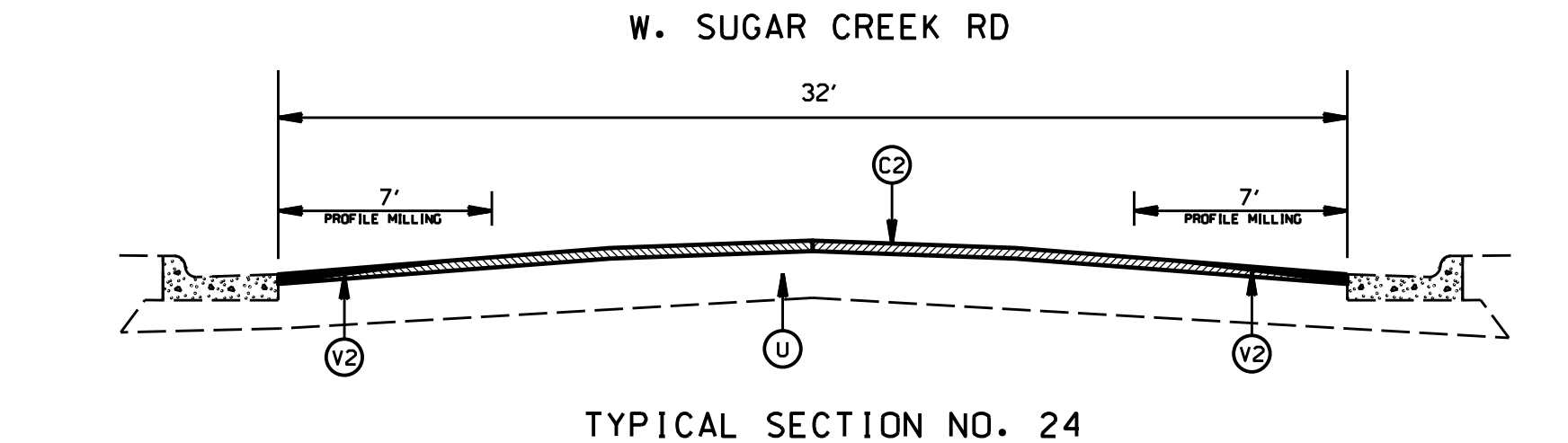
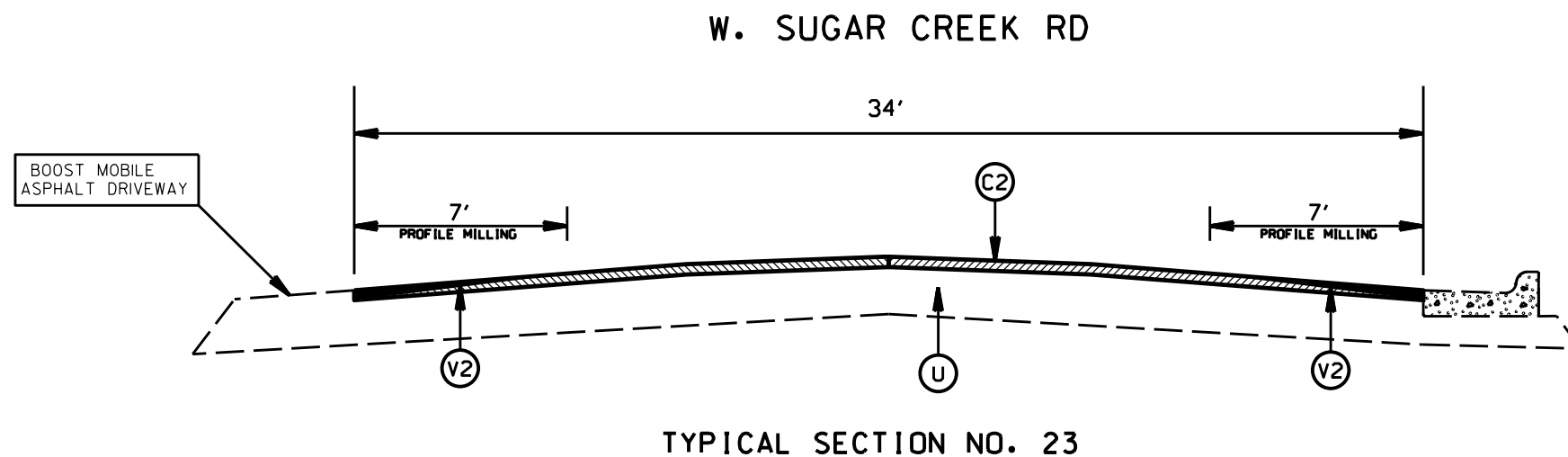

PATCHING DETAIL

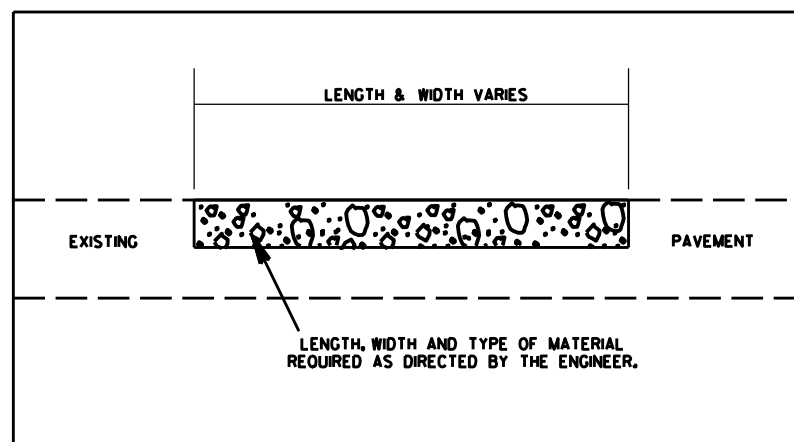

**2024 MECKLENBURG COUNTY
RESURFACING CONTRACT 1**

SCALE	-NA-		REVISIONS
DATE	7/23		
DWG. BY	JHE		
DESIGN BY	JHE		
APPROVED			

STATE	PROJECT NO.	SHEET NO.	TOTAL SHEETS
N.C.			
WBS NO.	2024CPT.J0.05.J0601 2024CPT.J0.05.20601		

PAVEMENT SCHEDULE	
C1	PROP. APPROX. 1.5" ASPHALT CONCRETE SURFACE COURSE, TYPE S9.5B, AT AN AVERAGE RATE OF 165 LBS. PER SQ. YD.
C2	PROP. APPROX. 1.5" ASPHALT CONCRETE SURFACE COURSE, TYPE S9.5C, AT AN AVERAGE RATE OF 168 LBS. PER SQ. YD.
C3	ASPHALT CONCRETE LEVELING COURSE, TYPE S9.5B, PLACED AT A VARIABLE RATE AS DIRECTED BY THE ENGINEER.
T	SHOULDER RECONSTRUCTION
U	EXISTING PAVEMENT
V1	MILLING 1.5" DEPTH
V2	PROFILE MILLING 0" TO 1.5"
V3	INCIDENTAL MILLING
Z	MILLED RUMBLE STRIPS

W. SUGAR CREEK RD

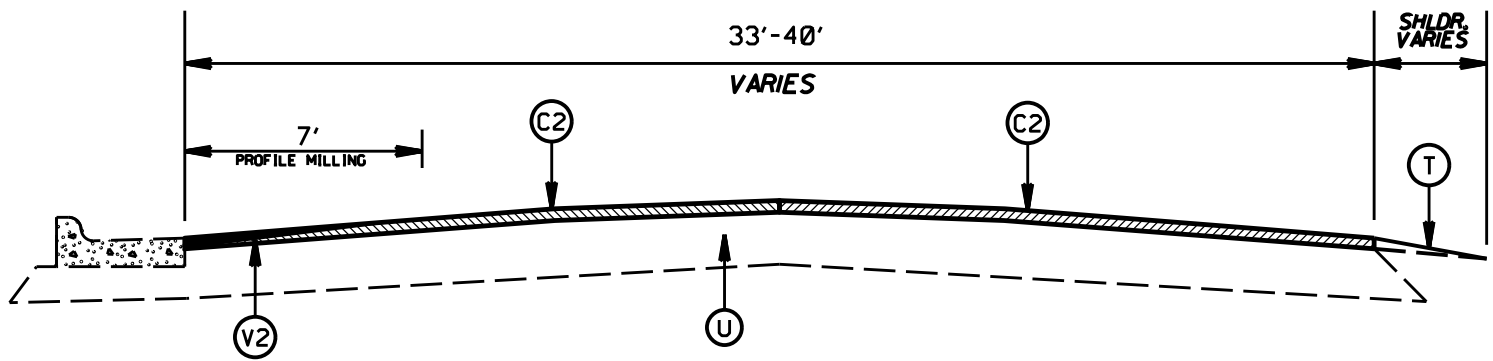

TYPICAL SECTION NO. 25

W. SUGAR CREEK RD

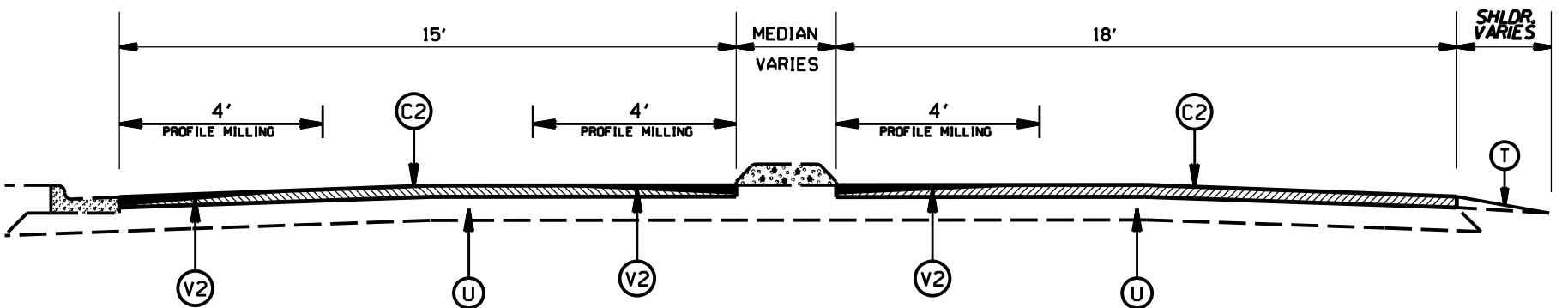

TYPICAL SECTION NO. 26

PATCHING DETAIL

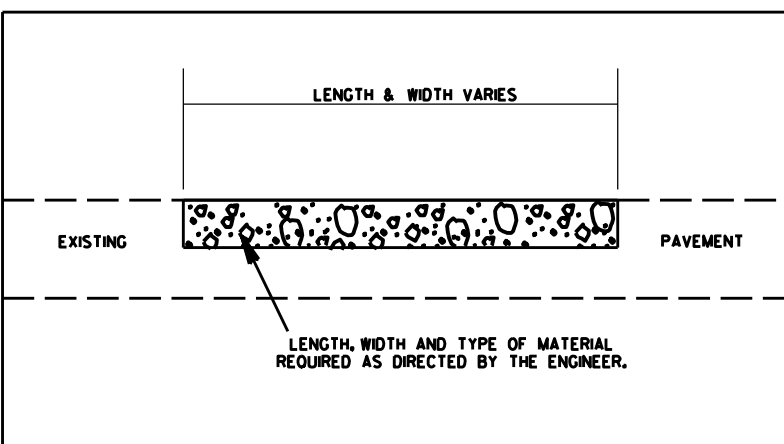

2024 MECKLENBURG COUNTY
RESURFACING CONTRACT 1

SCALE	-NA-		REVISIONS
DATE	7/23		
DWG. BY	JHE		
DESIGN BY	JHE		
APPROVED			

STATE	PROJECT NO.	SHEET NO.	TOTAL SHEETS
N.C.			
WBS NO.	2024CPT.J0.05.J0601 2024CPT.J0.05.20601		

PAVEMENT SCHEDULE	
C1	PROP. APPROX. 1.5" ASPHALT CONCRETE SURFACE COURSE, TYPE S9.5B, AT AN AVERAGE RATE OF 165 LBS. PER SQ. YD.
C2	PROP. APPROX. 1.5" ASPHALT CONCRETE SURFACE COURSE, TYPE S9.5C, AT AN AVERAGE RATE OF 168 LBS. PER SQ. YD.
C3	ASPHALT CONCRETE LEVELING COURSE, TYPE S9.5B, PLACED AT A VARIABLE RATE AS DIRECTED BY THE ENGINEER.
T	SHOULDER RECONSTRUCTION
U	EXISTING PAVEMENT
V1	MILLING 1.5" DEPTH
V2	PROFILE MILLING 0" TO 1.5"
V3	INCIDENTAL MILLING
Z	MILLED RUMBLE STRIPS

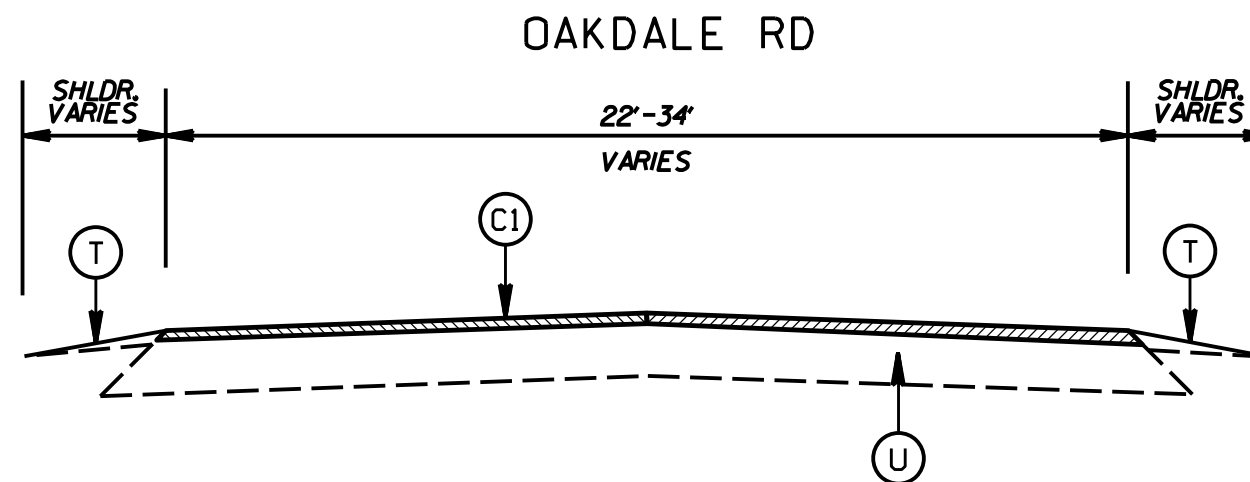

TYPICAL SECTION NO. 27

PATCHING DETAIL

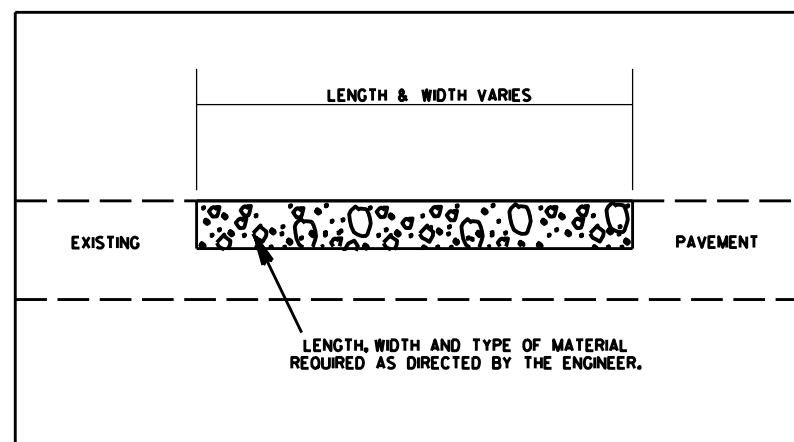

2024 MECKLENBURG COUNTY
RESURFACING CONTRACT 1

SCALE	-NA-		REVISIONS
DATE	7/23		
DWG. BY	JHE		
DESIGN BY	JHE		
APPROVED			

STATE	PROJECT NO.	SHEET NO.	TOTAL SHEETS
N.C.			
WBS NO.	2024CPT.10.05.10601 2024CPT.10.05.20601		

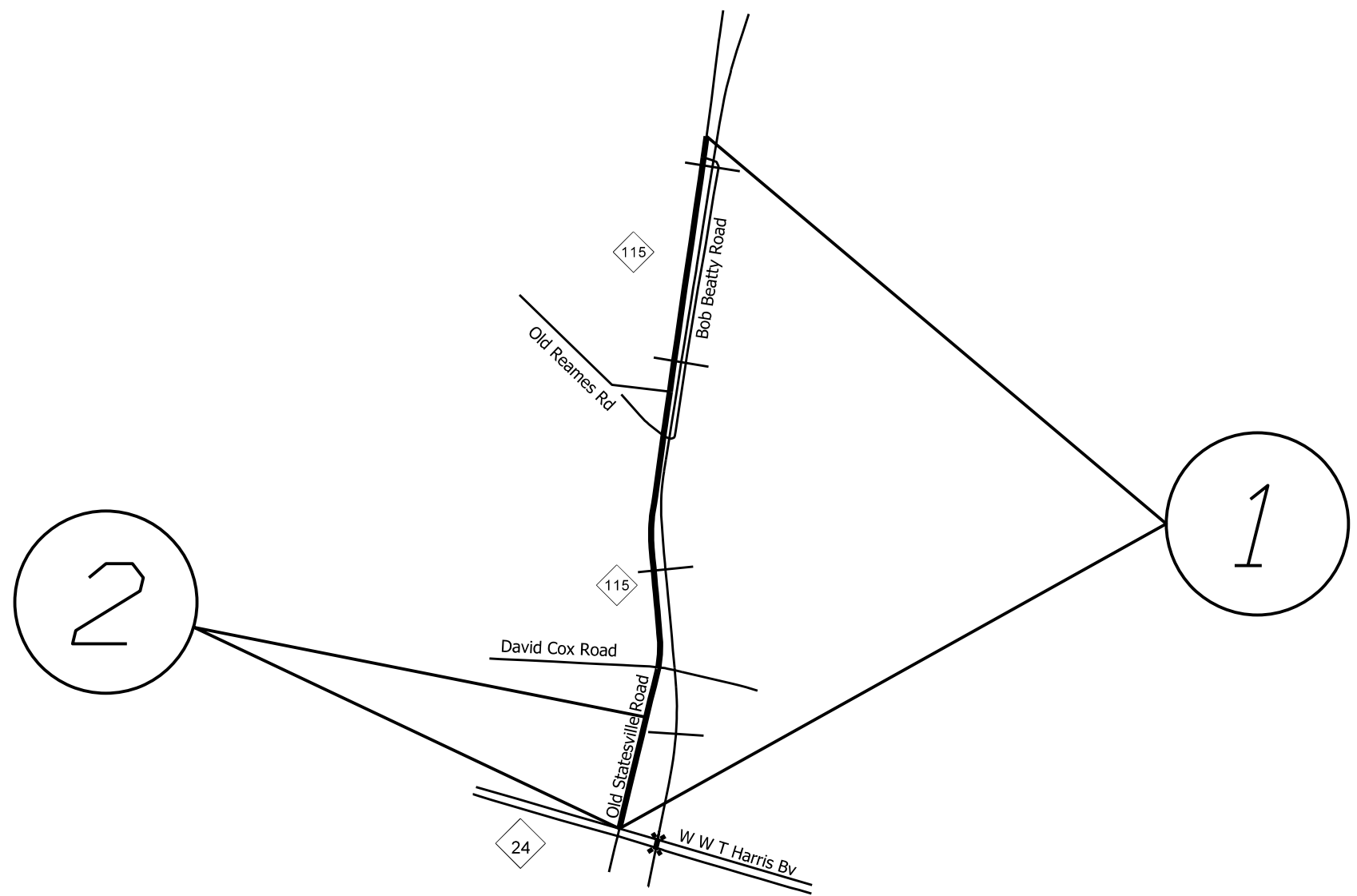

MAP

DESCRIPTION

- # 1 NC 115 OLD STATESVILLE ROAD
- # 2 NC 115 OLD STATESVILLE ROAD

- FROM W.T. HARRIS BLVD TO 0.10 MILES BEYOND BOB BEATTY ROAD
- FROM BEGIN DIVIDE TO W.T. HARRIS BLVD

2024 MECKLENBURG COUNTY RESURFACING CONTRACT 1		
SCALE	-NA-	
DATE	1/18	
DWG. BY	JHE	
DESIGN BY	JHE	
APPROVED		
		REVISIONS

STATE	PROJECT NO.	SHEET NO.	TOTAL SHEETS
N.C.			
WBS NO.	2024CPT.10.05.10601 2024CPT.10.05.20601		

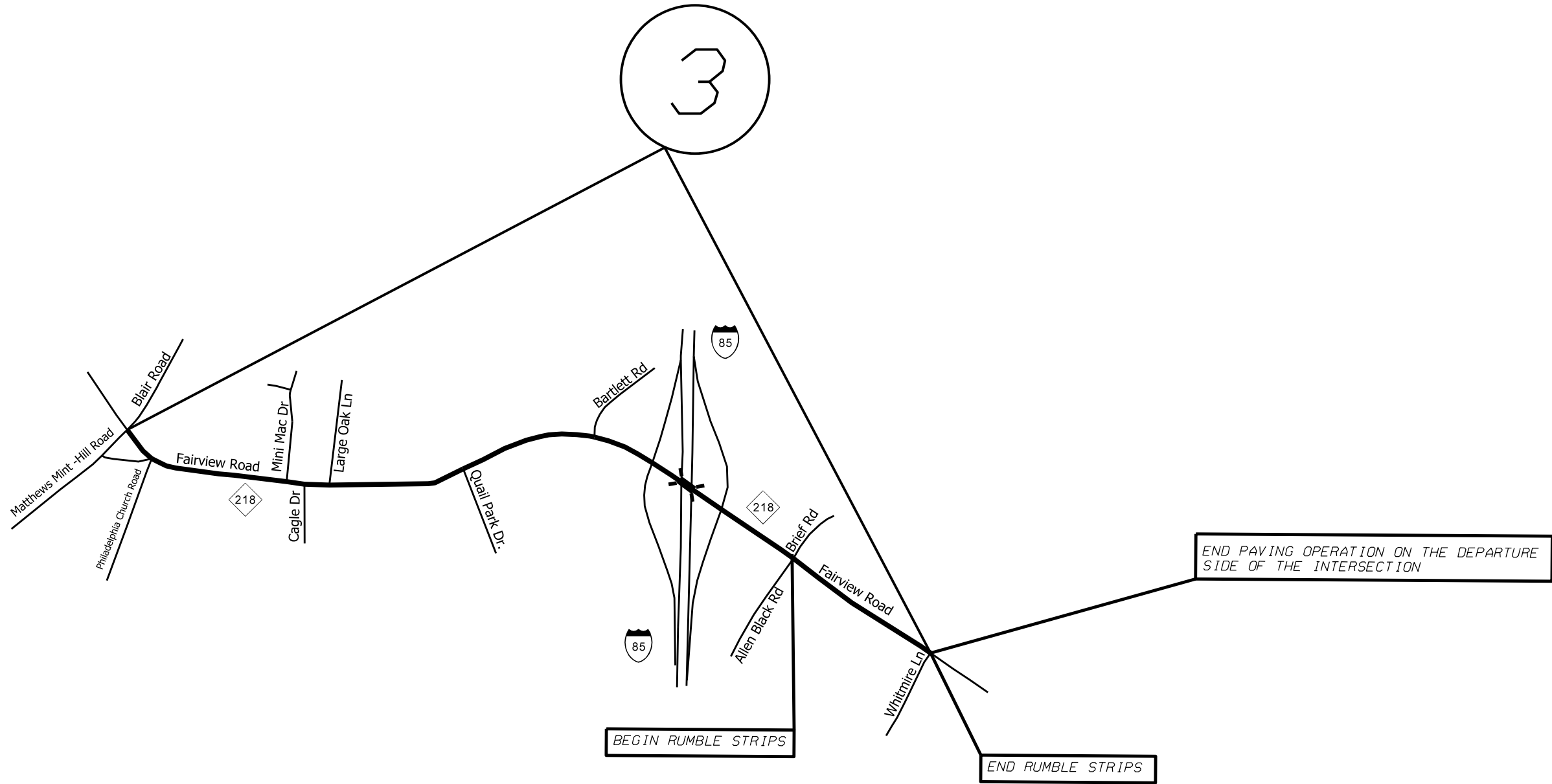

MAP

3 NC 218 FAIRVIEW ROAD

DESCRIPTION

FROM BLAIR ROAD TO WHITMIRE LANE

2024 MECKLENBURG COUNTY
RESURFACING CONTRACT 1

SCALE	-NA-		REVISIONS	
DATE	1/18			
DWG. BY	JHE			
DESIGN BY	JHE			
APPROVED				

STATE	PROJECT NO.	SHEET NO.	TOTAL SHEETS
N.C.			
WBS NO.	2024CPT.10.05.10601 2024CPT.10.05.20601		

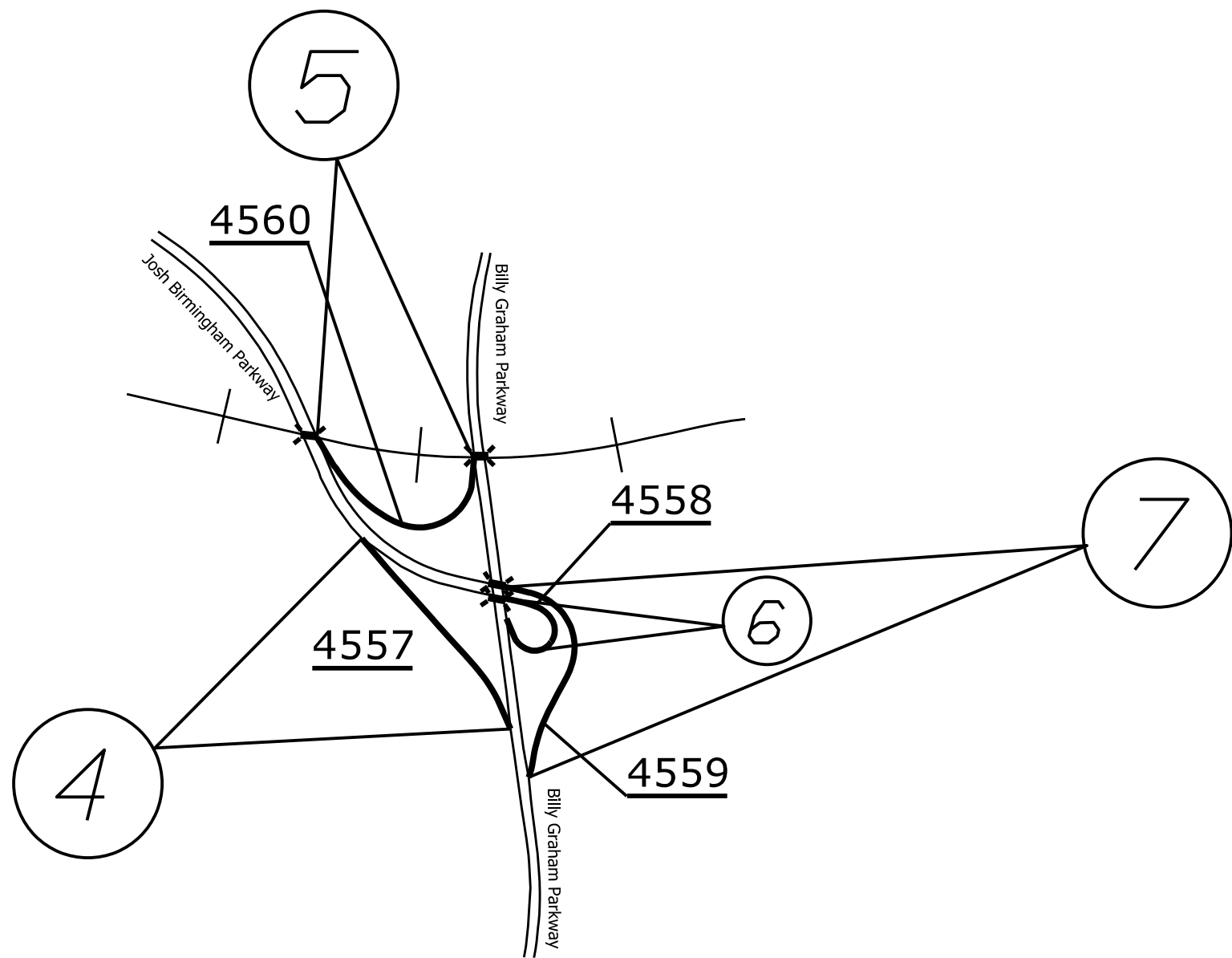

MAP

DESCRIPTION

- # 4 OFF RAMP SR 4557 JOSH BIRMINGHAM PKWY
- # 5 ON RAMP SR 4560 JOSH BIRMINGHAM PKWY
- # 6 OFF RAMP SR 4558 JOSH BIRMINGHAM PKWY
- # 7 ON RAMP SR 4559 JOSH BIRMINGHAM PKWY

- FROM ASPHALT PAVEMENT JOINT TO CONCRETE PAVEMENT JOINT
- FROM CONCRETE PAVEMENT JOINT TO ASPHALT PAVEMENT JOINT
- FROM BRIDGE DECK TO CONCRETE PAVEMENT JOINT
- FROM CONCRETE PAVEMENT JOINT TO BRIDGE DECK

2024 MECKLENBURG COUNTY
RESURFACING CONTRACT 1

SCALE	-NA-		REVISIONS
DATE	1/18		
DWG. BY	JHE		
DESIGN BY	JHE		
APPROVED			

STATE	PROJECT NO.	SHEET NO.	TOTAL SHEETS
N.C.			
WBS NO. 2024CPT.10.05.10601 2024CPT.10.05.20601			

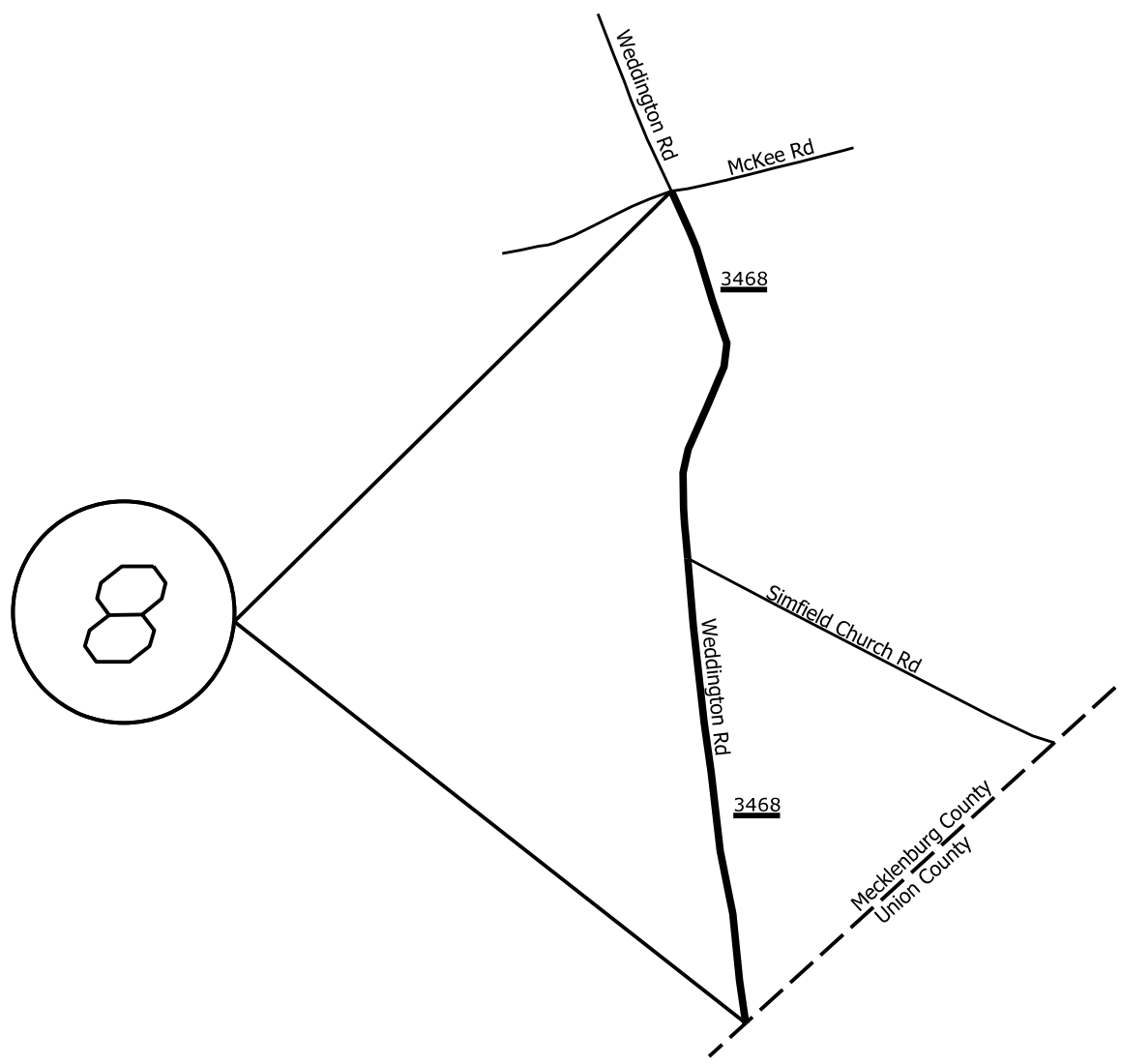

NOTE:
LEVELING COURSE S9.5B TO BE PLACED AT VARIOUS LOCATIONS AS DIRECTED BY THE ENGINEER.

MAP

DESCRIPTION

8 SR 3468 WEDDINGTON ROAD

FROM UNION COUNTY LINE TO MCKEE ROAD

2024 MECKLENBURG COUNTY RESURFACING CONTRACT 1				
SCALE	-NA-		REVISIONS	
DATE	1/18			
DWG. BY	JHE			
DESIGN BY	JHE			
APPROVED				

STATE	PROJECT NO.	SHEET NO.	TOTAL SHEETS
N.C.			
WBS NO.	2024CPT.10.05.10601 2024CPT.10.05.20601		

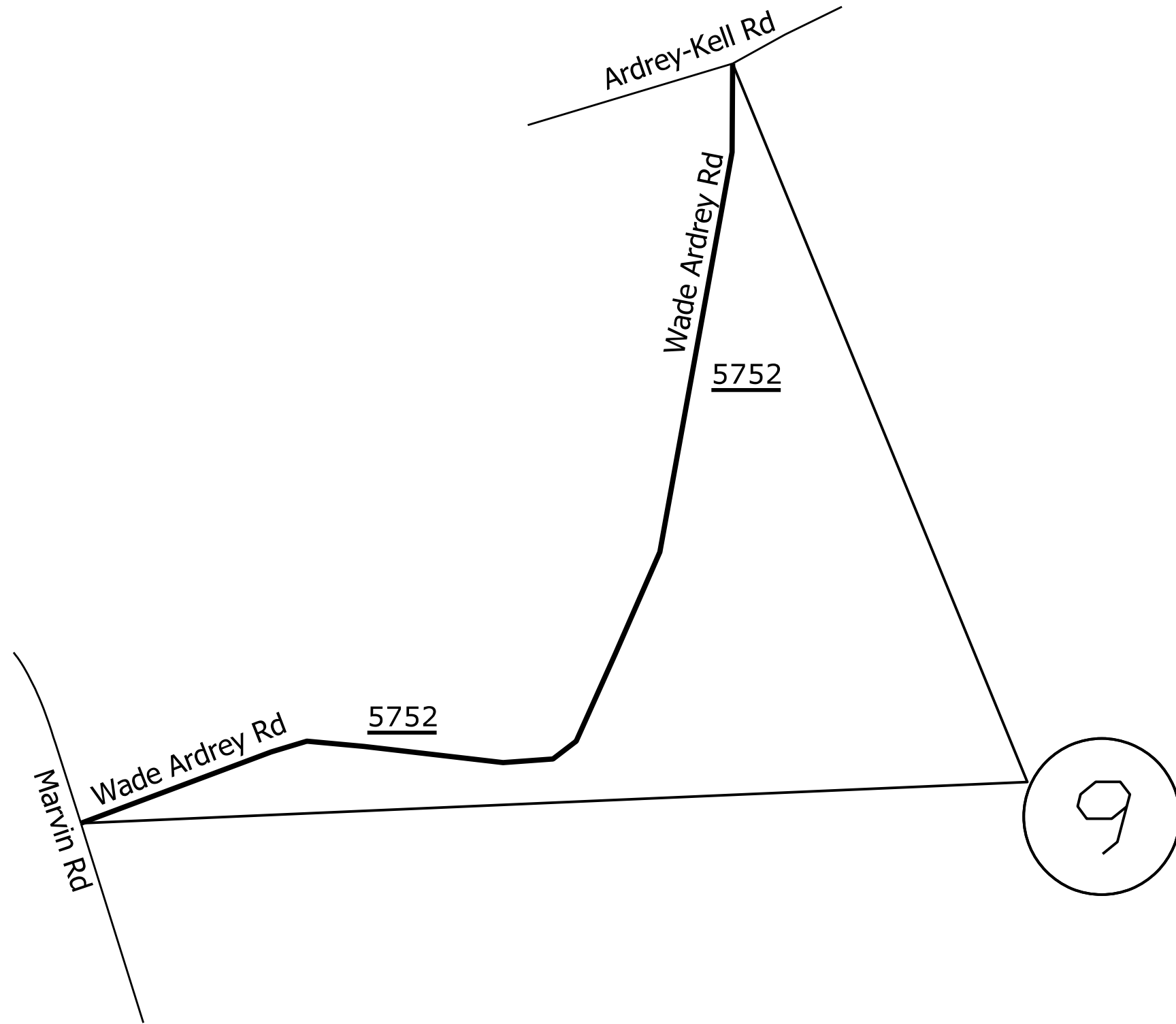

MAP

DESCRIPTION

9 SR 5752 WADE ARDREY ROAD

FROM ARDREY KELL ROAD TO MARVIN ROAD

2024 MECKLENBURG COUNTY
RESURFACING CONTRACT 1

SCALE	-NA-		REVISIONS	
DATE	1/18			
DWG. BY	JHE			
DESIGN BY	JHE			
APPROVED				

STATE	PROJECT NO.	SHEET NO.	TOTAL SHEETS
N.C.			
WBS NO.	2024CPT.10.05.10601 2024CPT.10.05.20601		

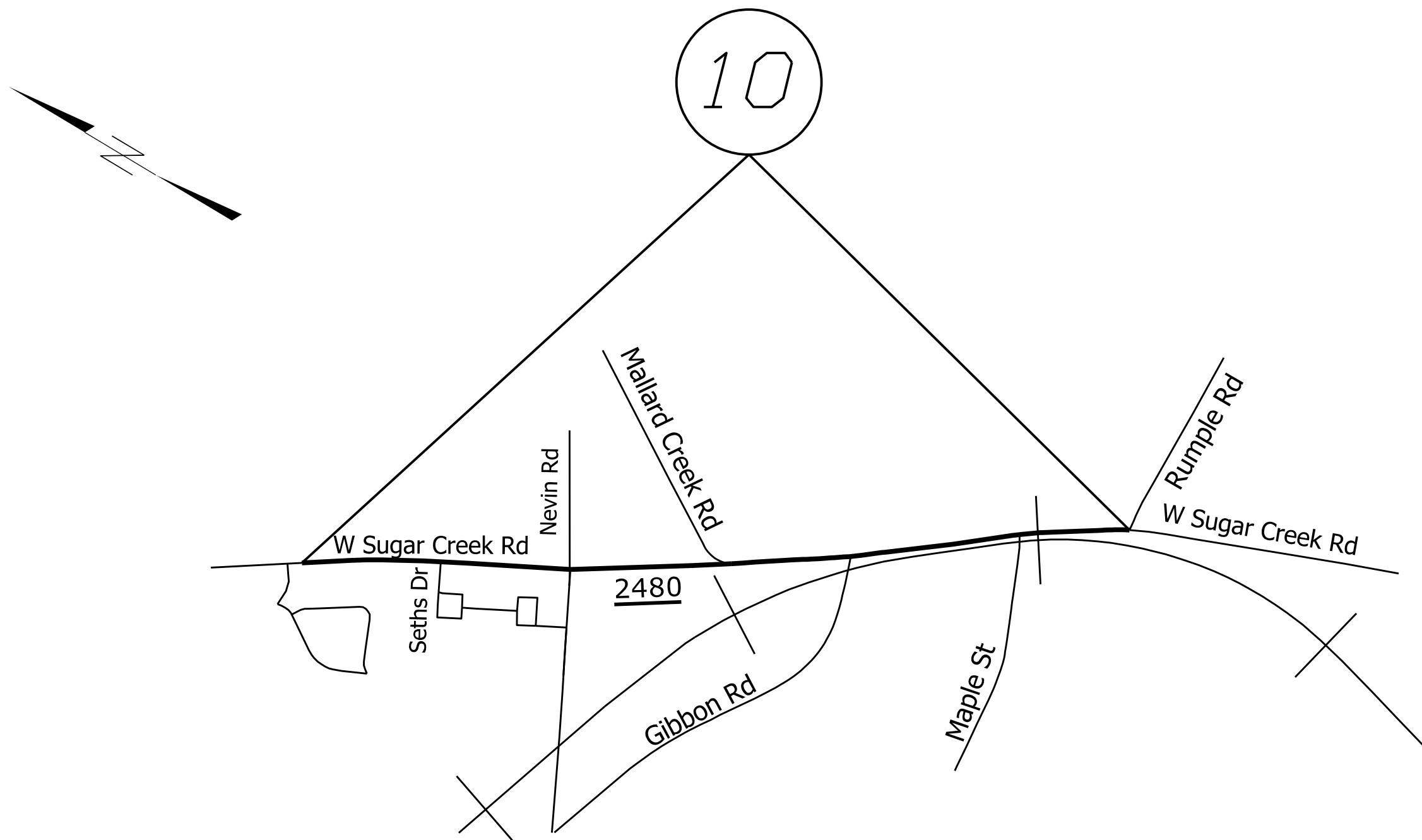

MAP

10 SR 2480 W SUGAR CREEK ROAD

DESCRIPTION

FROM RUMPLE RD TO 0.10 MI BEYOND SETHS DR

2024 MECKLENBURG COUNTY
RESURFACING CONTRACT 1

SCALE	-NA-		REVISIONS	
DATE	1/18			
DWG. BY	JHE			
DESIGN BY	JHE			
APPROVED				

STATE	PROJECT NO.	SHEET NO.	TOTAL SHEETS
N.C.			
WBS NO.	2024CPT . 10 . 05 . 10601 2024CPT . 10 . 05 . 20601		

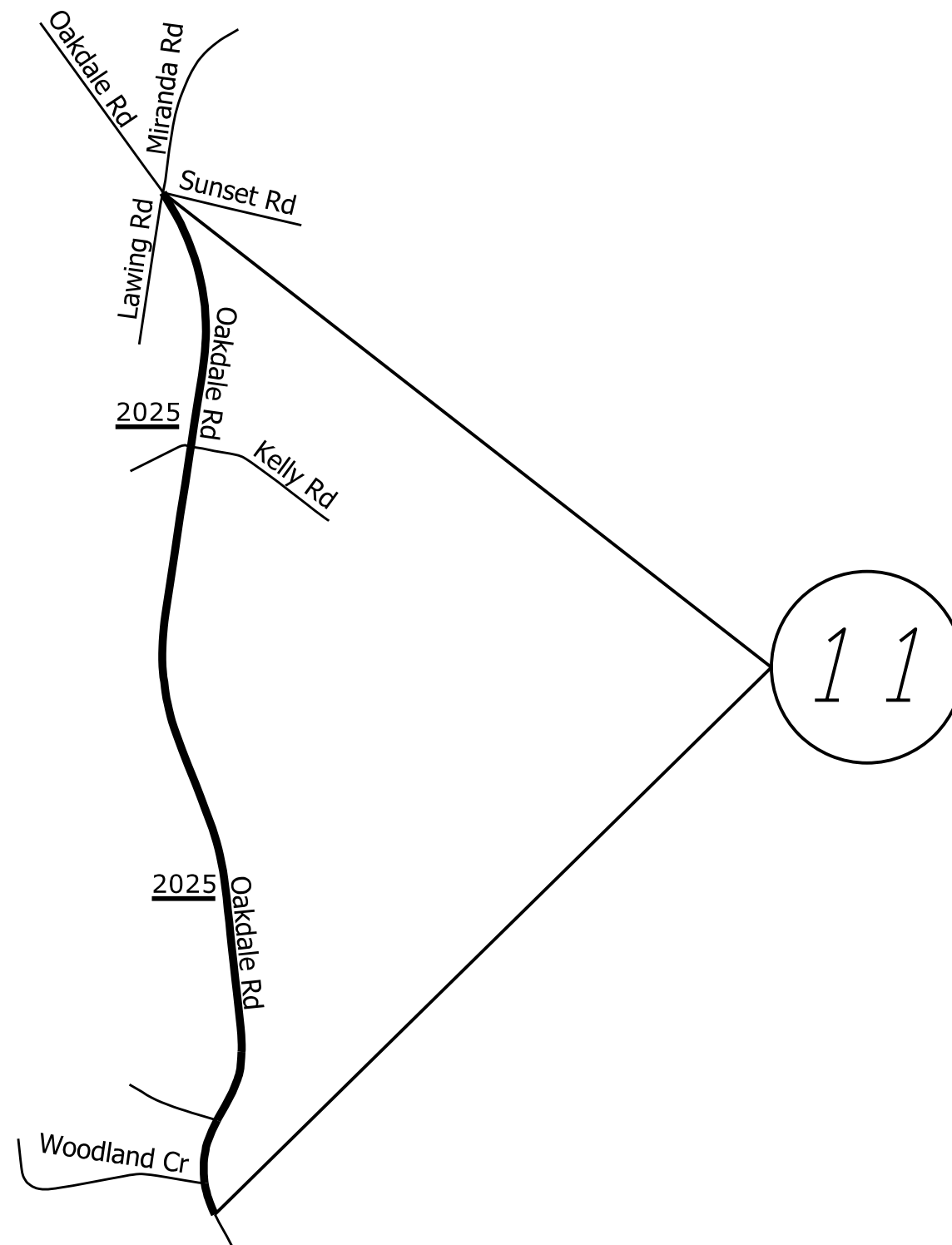

MAP

11 SR 2025 OAKDALE ROAD

DESCRIPTION

FROM 0.03 MI PRIOR TO WOODLAND CIRCLE
TO MIRANDA RD

2024 MECKLENBURG COUNTY RESURFACING CONTRACT I		
SCALE	-MA-	
DATE	1/18	
DWG. BY	JHE	
DESIGN BY	JHE	
APPROVED		
		REVISIONS

COIR FIBER WATTLE WITH POLYACRYLAMIDE (PAM) DETAIL

PROJECT REFERENCE NO.	SHEET NO.
RW. SHEET NO.	
ROADWAY DESIGN ENGINEER	HYDRAULICS ENGINEER

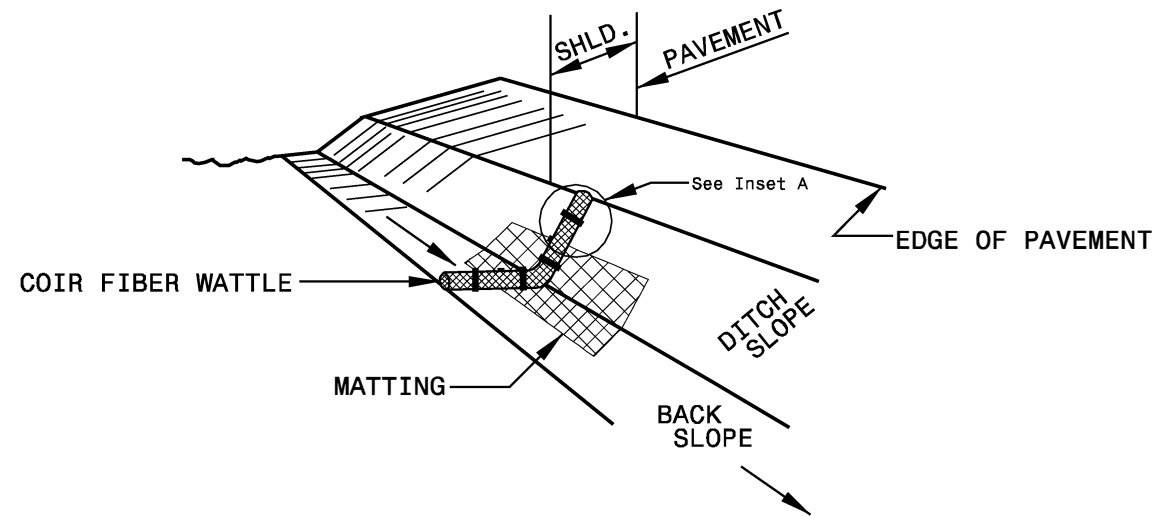

ISOMETRIC VIEW

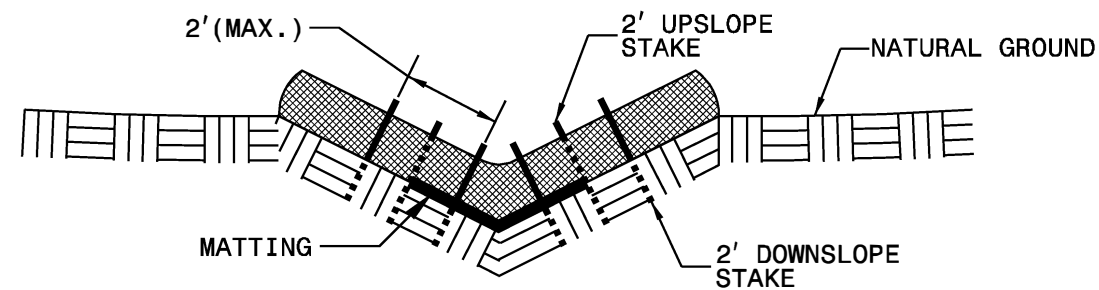

CROSS SECTION VEE DITCH

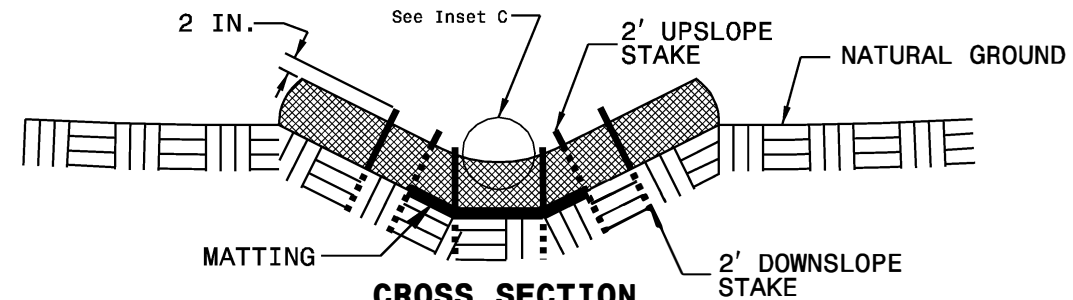

CROSS SECTION TRAPEZOIDAL DITCH

NOTES:

USE MINIMUM 12 IN. DIAMETER COIR FIBER (COCONUT FIBER) WATTLE.

USE 2 FT. WOODEN STAKES WITH A 2 IN. BY 2 IN. NOMINAL CROSS SECTION.

ONLY INSTALL WATTLE(S) TO A HEIGHT IN DITCH SO FLOW WILL NOT WASH AROUND WATTLE AND SCOUR DITCH SLOPES AND AS DIRECTED.

INSTALL A MINIMUM OF 2 UPSLOPE STAKES AND 4 DOWNSLOPE STAKES AT AN ANGLE TO WEDGE WATTLE TO BOTTOM OF DITCH.

PROVIDE STAPLES MADE OF 0.125 IN. DIAMETER STEEL WIRE FORMED INTO A U SHAPE NOT LESS THAN 12" IN LENGTH.

INSTALL STAPLES APPROXIMATELY EVERY 1 LINEAR FOOT ON BOTH SIDES OF WATTLE AND AT EACH END TO SECURE IT TO THE SOIL.

INSTALL MATTING IN ACCORDANCE WITH SECTION 1631 OF THE STANDARD SPECIFICATIONS.

PRIOR TO POLYACRYLAMIDE (PAM) APPLICATION, OBTAIN A SOIL SAMPLE FROM PROJECT LOCATION, AND FROM OFFSITE MATERIAL, AND ANALYZE FOR APPROPRIATE PAM FLOCCULANT TO BE APPLIED TO EACH WATTLE.

INITIALLY APPLY 2 OUNCES OF ANIONIC OR NEUTRALLY CHARGED PAM OVER WATTLE WHERE WATER WILL FLOW AND 1 OUNCE OF PAM ON MATTING ON EACH SIDE OF WATTLE. REAPPLY PAM AFTER EVERY RAINFALL EVENT THAT IS EQUAL TO OR EXCEEDS 0.50 IN.

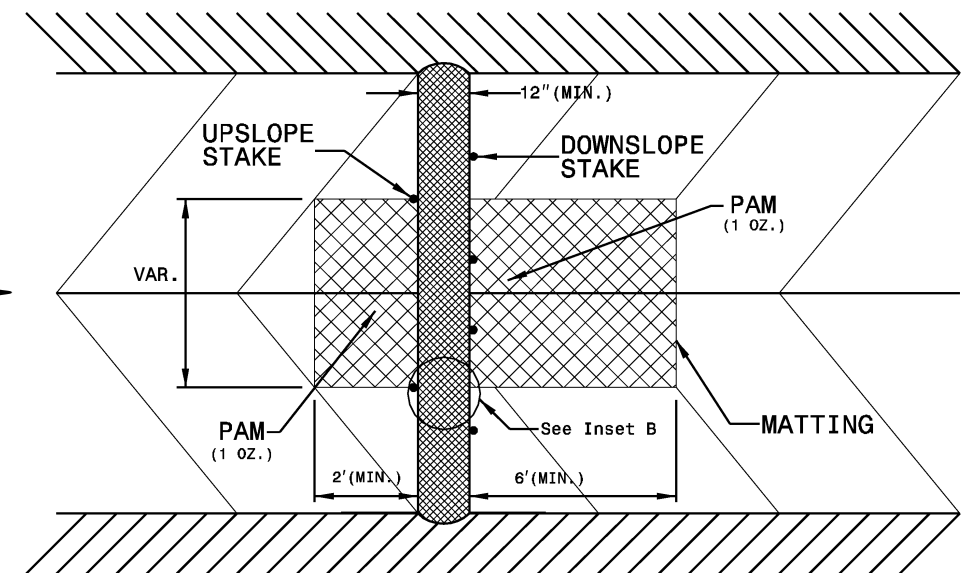
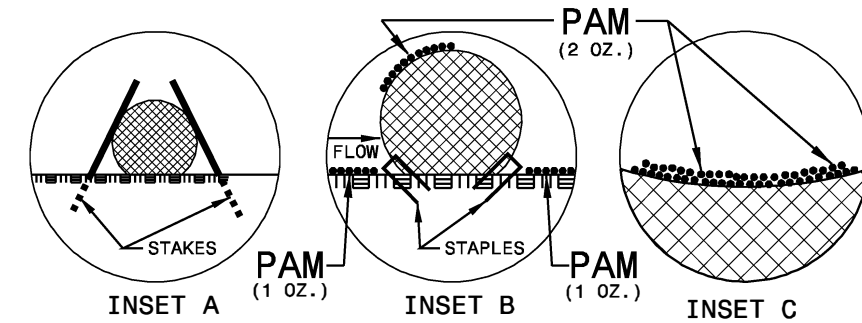

TOP VIEW

5/14/99

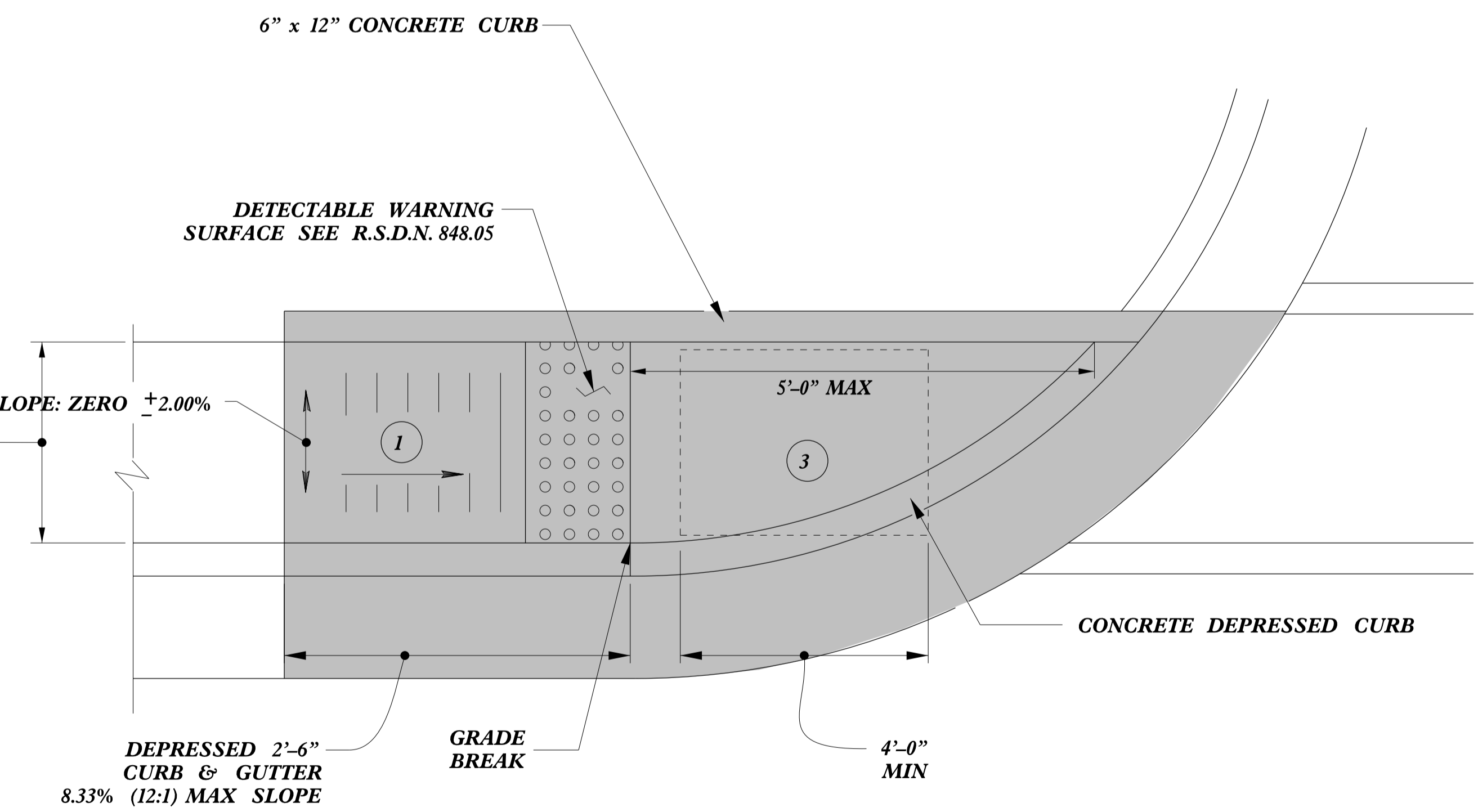
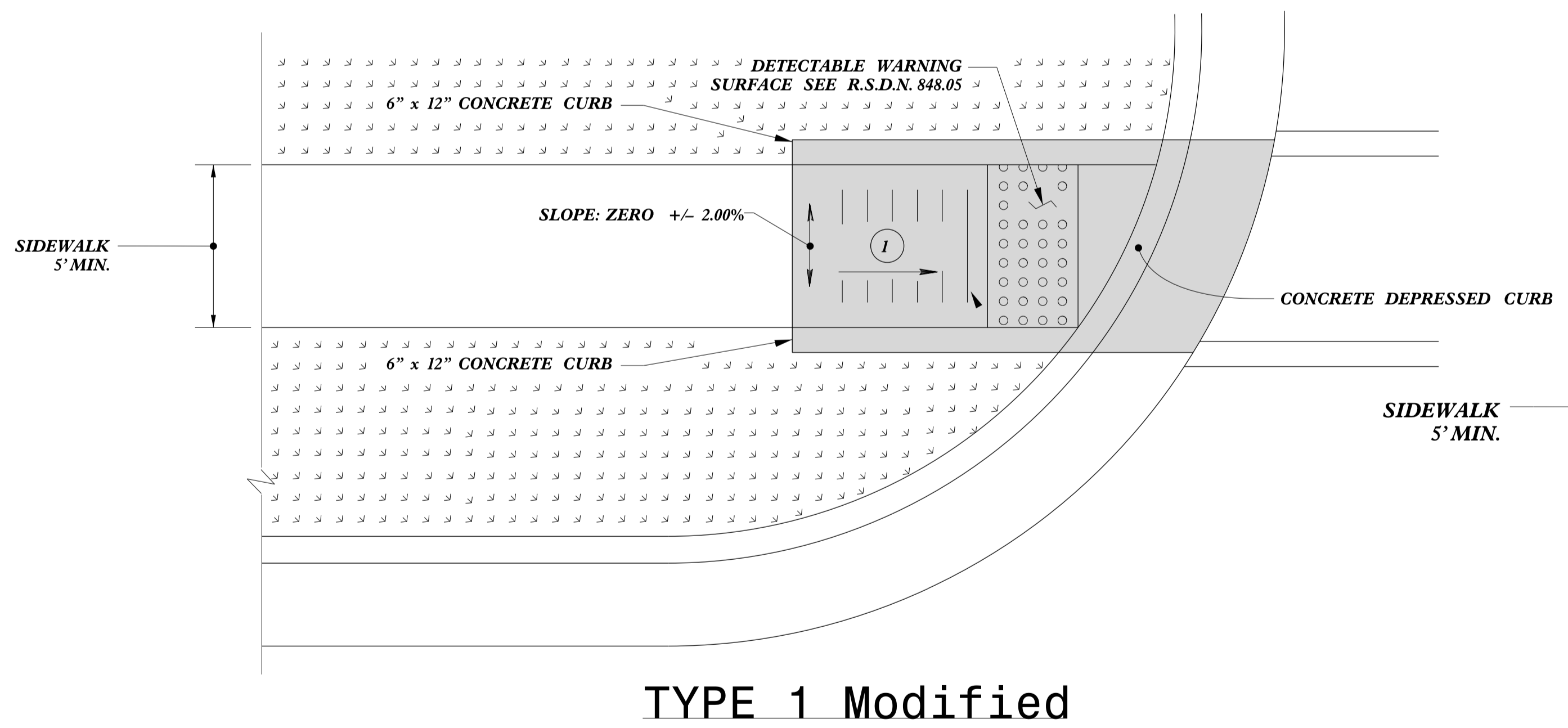
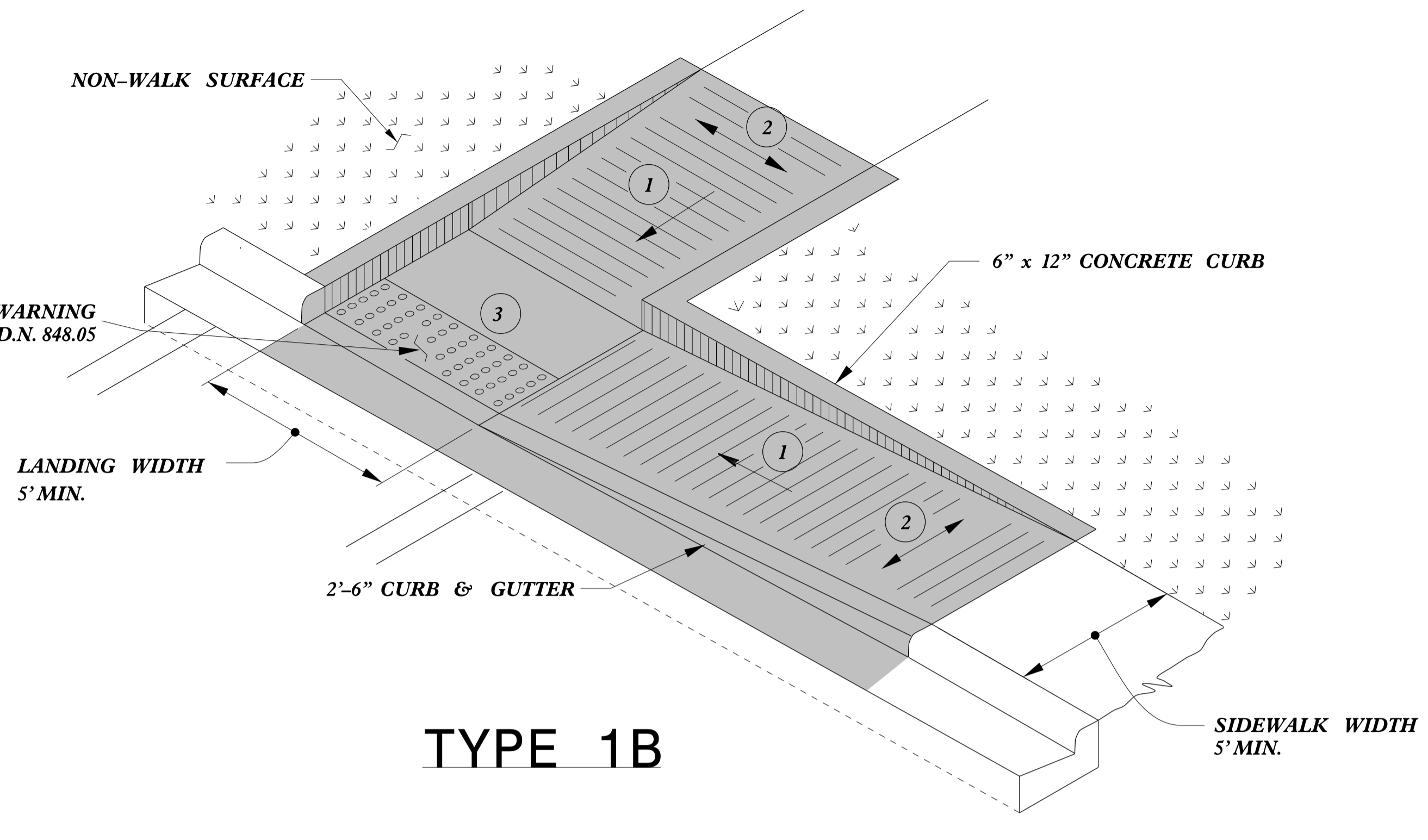
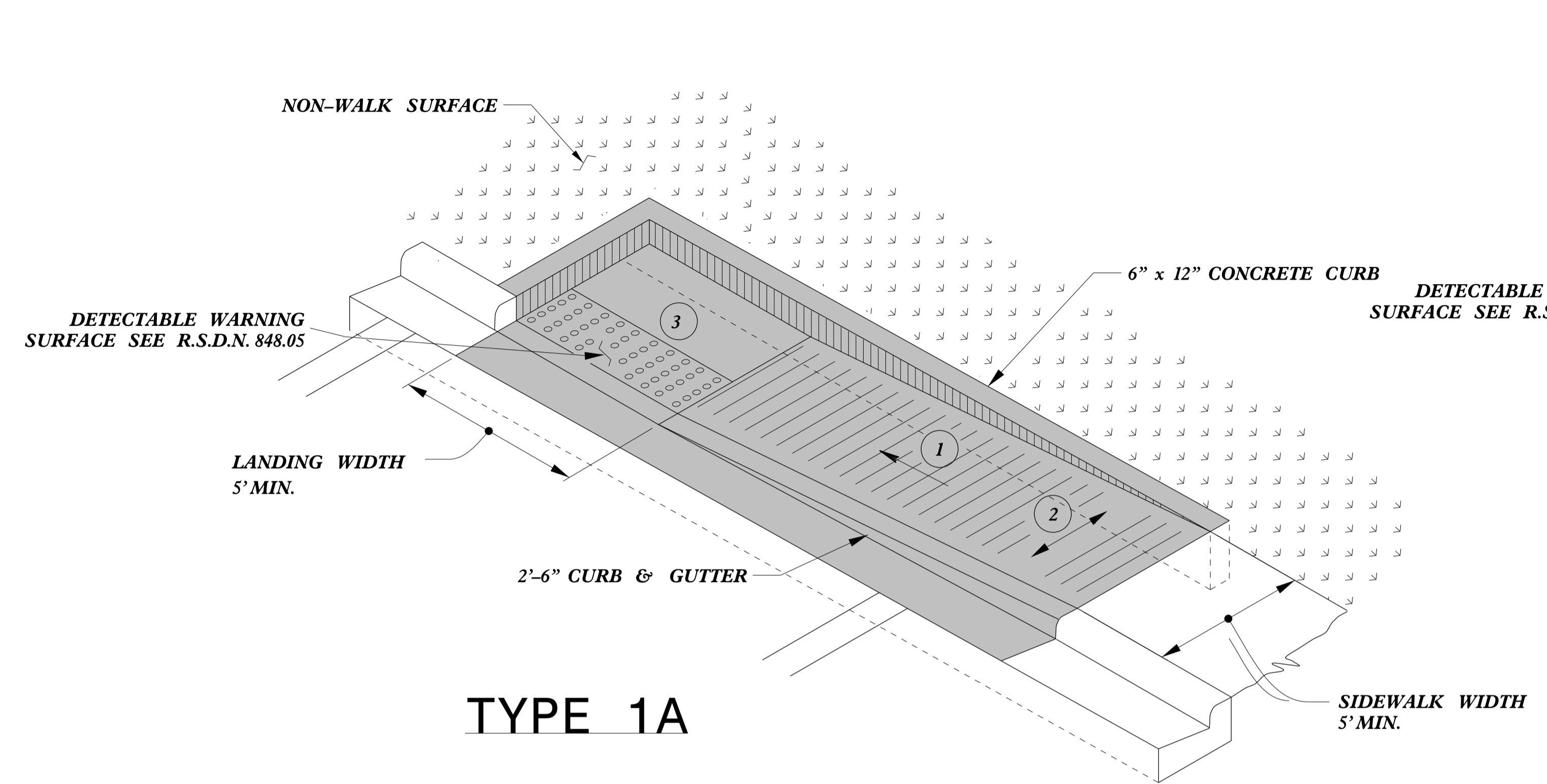

- 1 8.33% (12:1) MAX RAMP SLOPE
- 2 CROSS SLOPE: 2.00%
- 3 CURB RAMPS REQUIRE A (4'-0") MINIMUM LANDING WITH A MAXIMUM CROSS SLOPE AND LONGITUDINAL SLOPE OF 2.00% WHERE PEDESTRIANS PERFORM TURNING MANEUVERS. SLOPE TO DRAIN TO CURB.



PAY LIMITS FOR 1 CURB RAMP

REFER TO ROADWAY STANDARD DRAWING NUMBER 848.05 SHEET 3 OF 3 FOR ALL RAMP NOTES



DOCUMENT NOT CONSIDERED FINAL UNLESS ALL SIGNATURES COMPLETED

CONTRACT STANDARDS AND DEVELOPMENT UNIT	
Office 919-707-6950	FAX 919-250-4119
CURB RAMPS	
Directional Ramps	
ORIGINAL BY: J.S. HOWERTON	DATE: 7/7/11
MODIFIED BY:	DATE:
CHECKED BY:	DATE:
FILE SPEC.:stds/2012CurbRamp/CurbRampDetails.dgn	

C:\P\2011\110825\110825.dwg
 11/14/11 10:58:58 AM
 J.S. HOWERTON
 87350170DCD45F

5/14/99

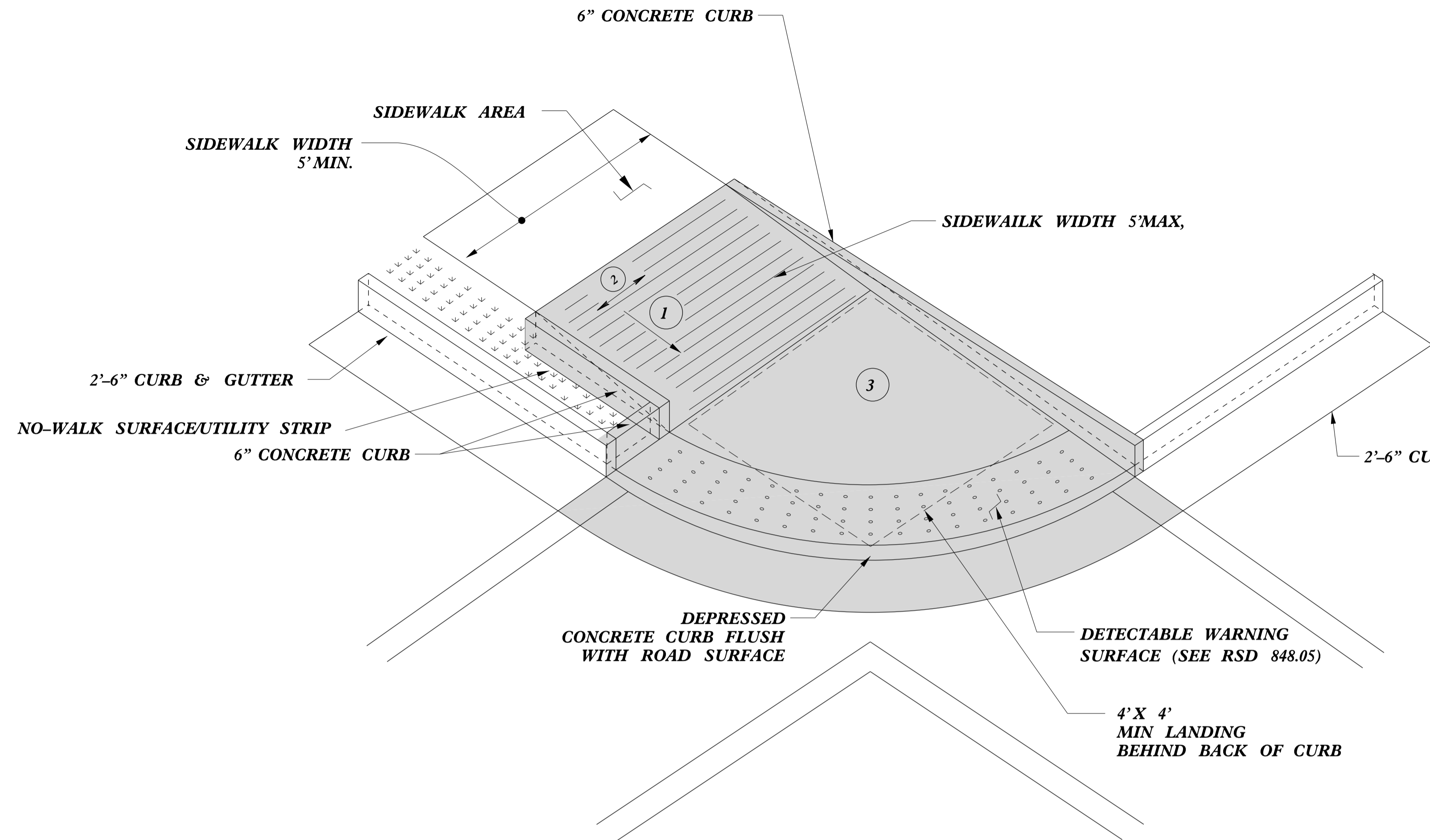

TYPE 2A MOD

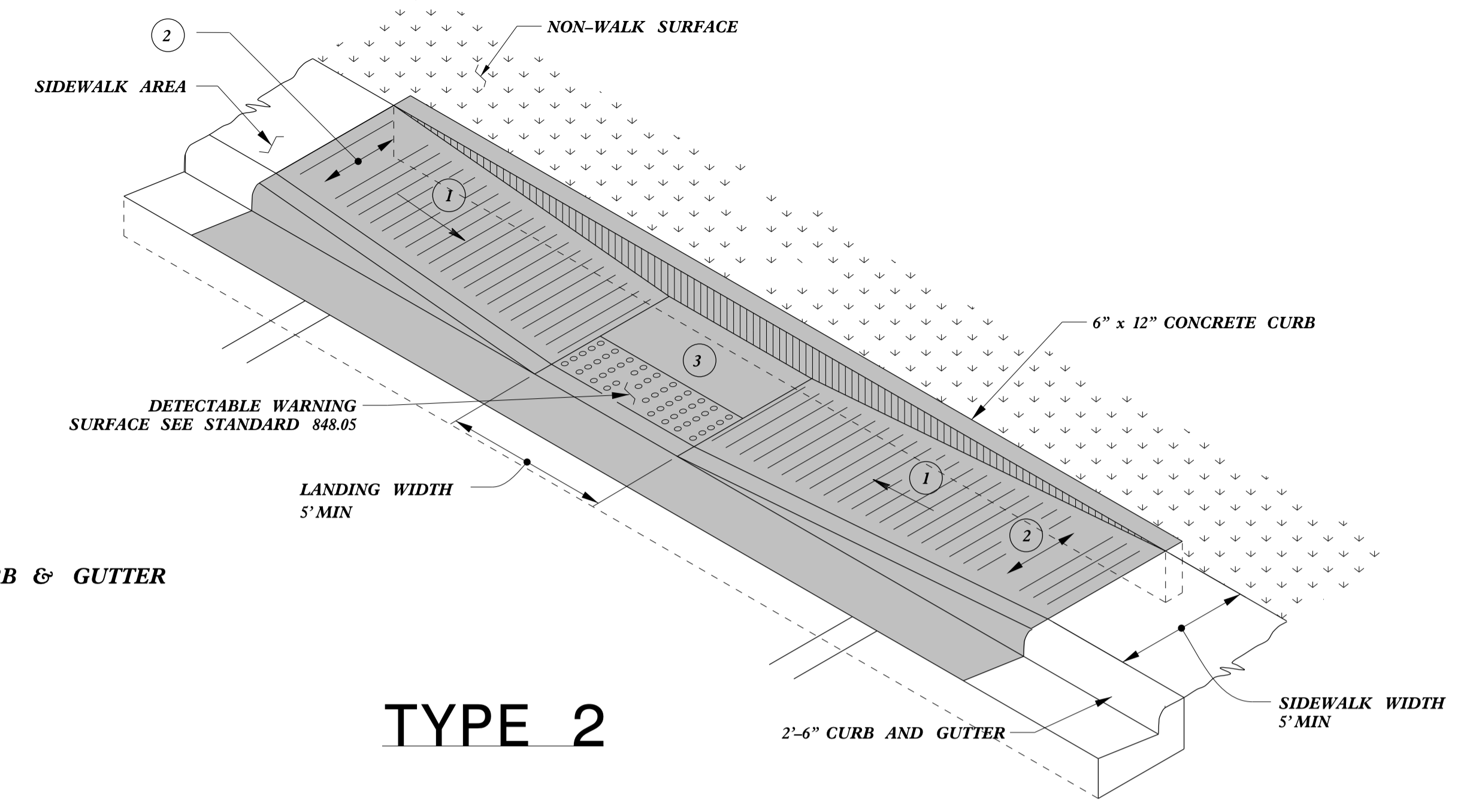

TYPE 2

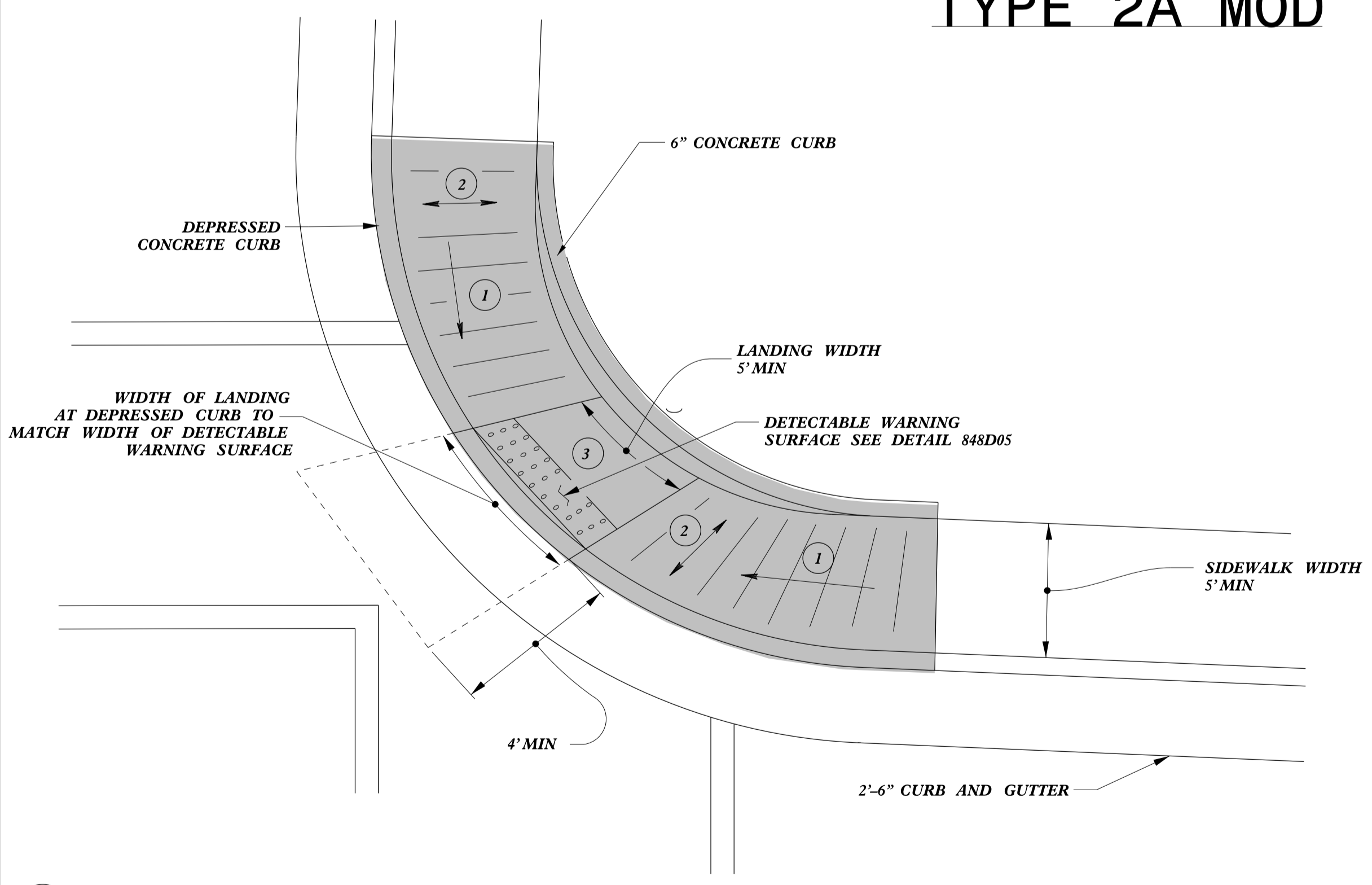

TYPE 2B

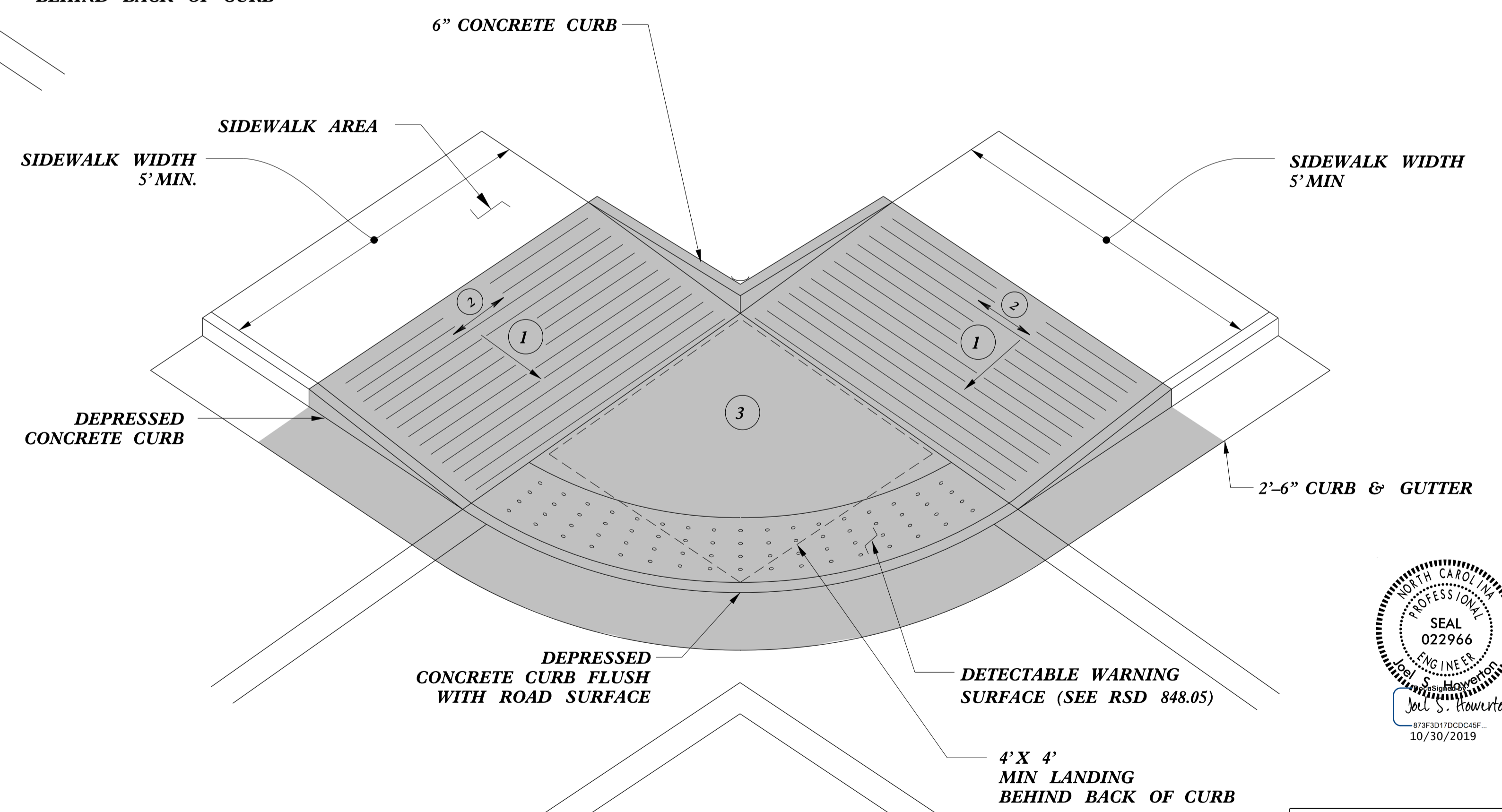

TYPE 2A

- 1 8.33% (12:1) MAX RAMP SLOPE
- 2 CROSS SLOPE: 2.00%
- 3 CURB RAMPS REQUIRE A (4'-0") MINIMUM LANDING WITH A MAXIMUM CROSS SLOPE AND LONGITUDINAL SLOPE OF 2.00% WHERE PEDESTRIANS PERFORM TURNING MANEUVERS. SLOPE TO DRAIN TO CURB.

PAY LIMITS FOR 1 CURB RAMP

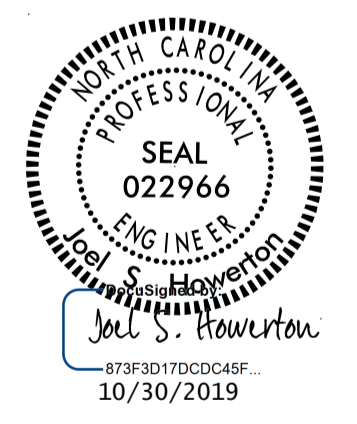

DOCUMENT NOT CONSIDERED FINAL UNLESS ALL SIGNATURES COMPLETED

CONTRACT STANDARDS AND DEVELOPMENT UNIT	
Office 919-707-6950	FAX 919-250-4119
CURB RAMPS	
ORIGINAL BY: J.S. HOWERTON	DATE: 7/7/11
MODIFIED BY:	DATE:
CHECKED BY:	DATE:
FILE SPEC.: stds/2012CurbRamp/CurbRampDetails.dgn	

TIME: 11:00 AM 11/14/2019
 CURB RAMPS.dwg
 J.S. HOWERTON
 PROJECT: 10/30/2019

PAY LIMITS FOR 1 CURB RAMP

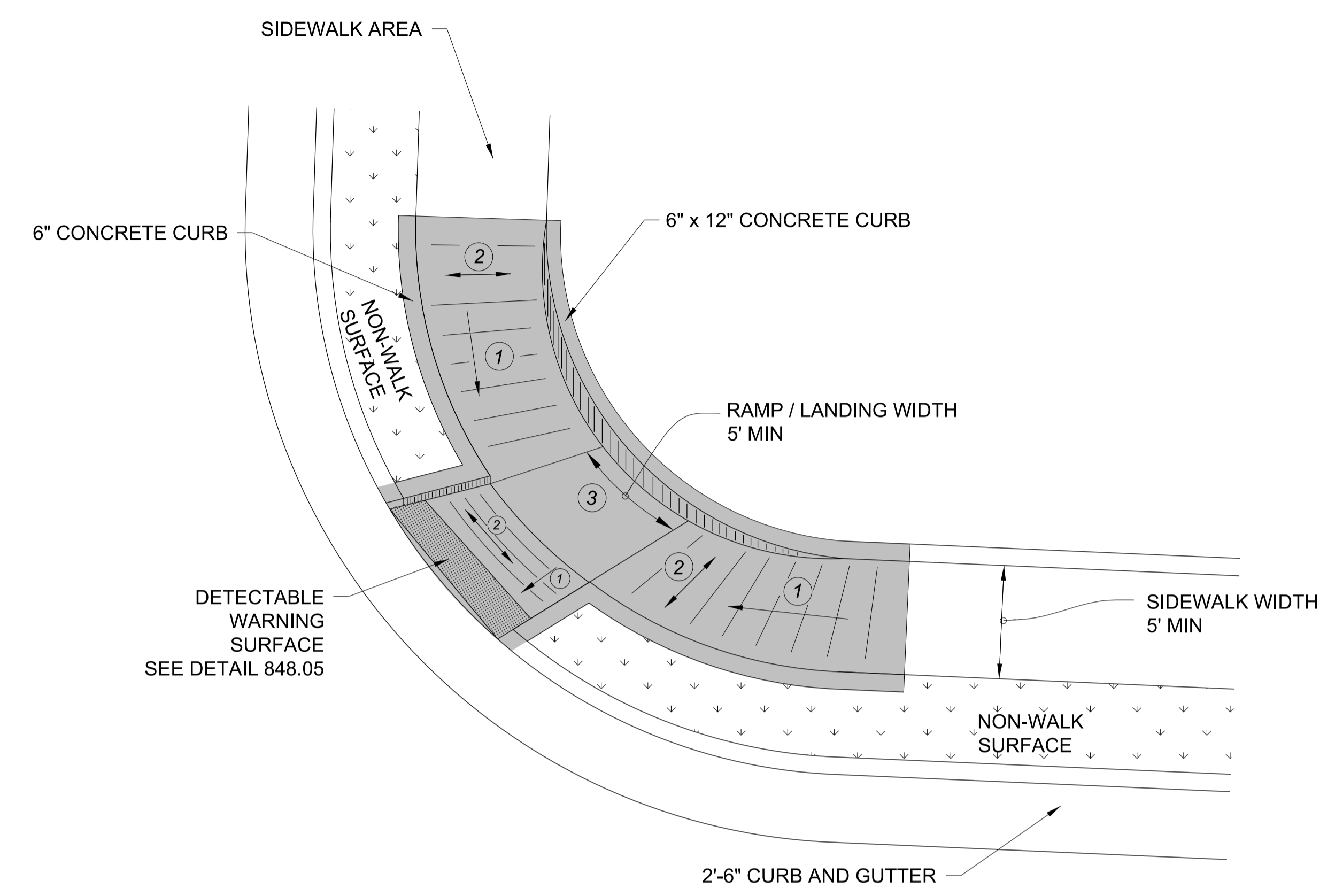

**TYPE 3 MODIFIED
INSTALLATION IN A RADIUS**

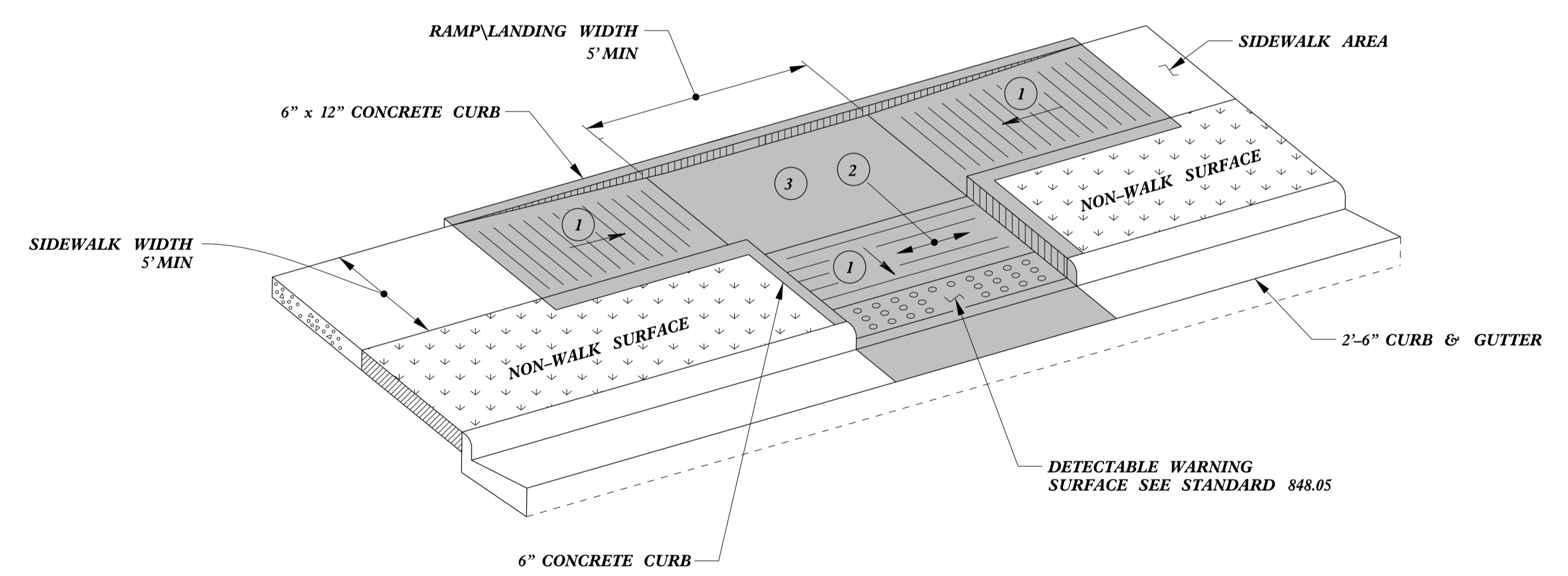

TYPE 3

- 1 8.33% (12:1) MAX RAMP SLOPE
- 2 CROSS SLOPE: 2.00%
- 3 CURB RAMPS REQUIRE A (4'-0") MINIMUM LANDING WITH A MAXIMUM CROSS SLOPE AND LONGITUDINAL SLOPE OF 2.00% WHERE PEDESTRIANS PERFORM TURNING MANEUVERS. SLOPE TO DRAIN TO CURB.



DOCUMENT NOT CONSIDERED FINAL UNLESS ALL SIGNATURES COMPLETED

CONTRACT STANDARDS AND DEVELOPMENT UNIT	
Office 919-707-6950	FAX 919-250-4119
CURB RAMPS	
ORIGINAL BY: J.S. HOWERTON	DATE: 7/7/11
MODIFIED BY:	DATE:
CHECKED BY:	DATE:
FILE SPEC.:stds/2012CurbRamp/CurbRampDetails.dgn	

5/14/99
C:\P\2012\STDS\2012CurbRamp\CurbRampDetails.dgn

PAY LIMITS FOR 1 OR 2 CURB RAMPS
(CALCULATE BASED ON NUMBER OF SETS
OF TRUNCATED DOMES)

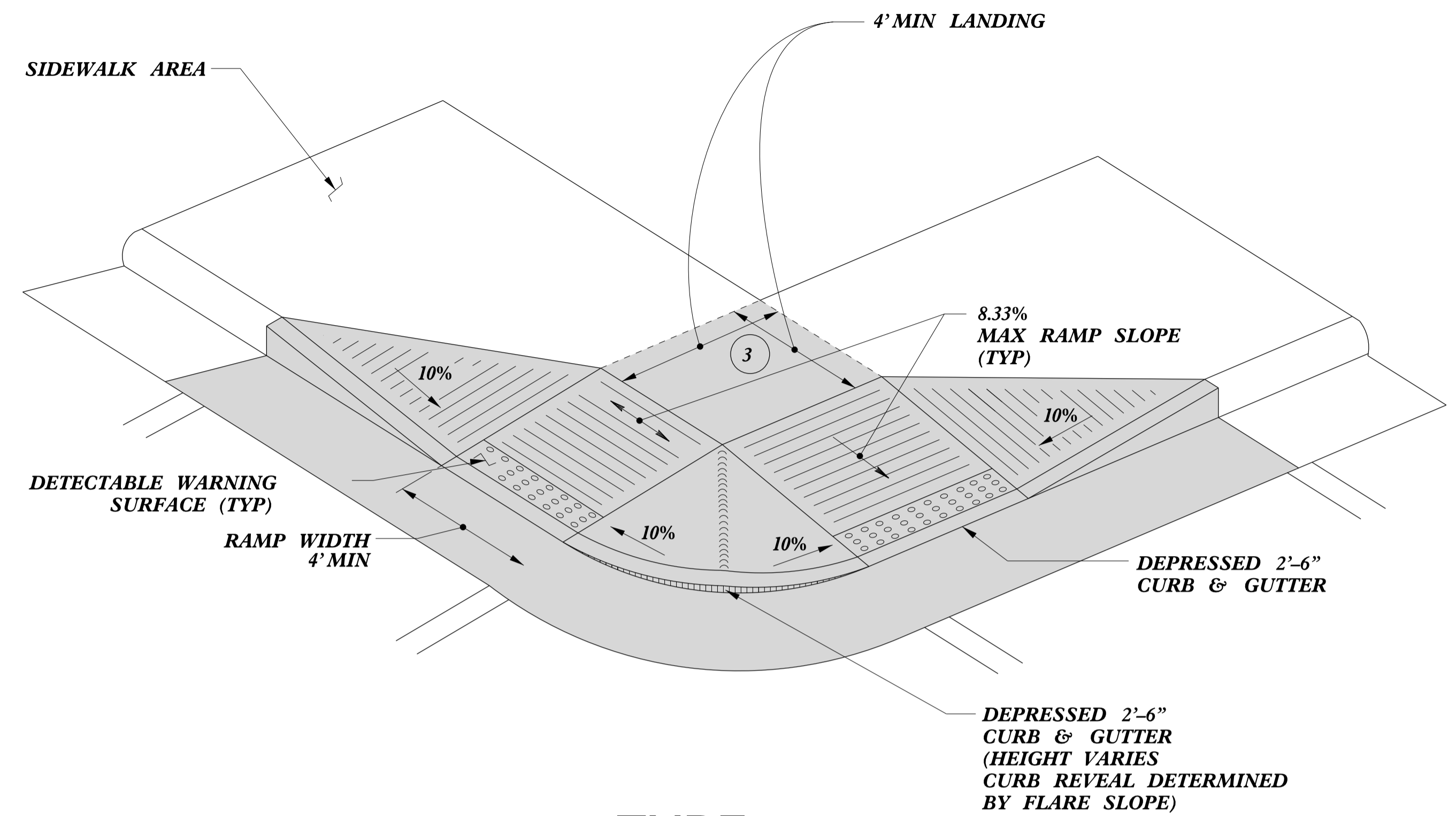

TYPE 4

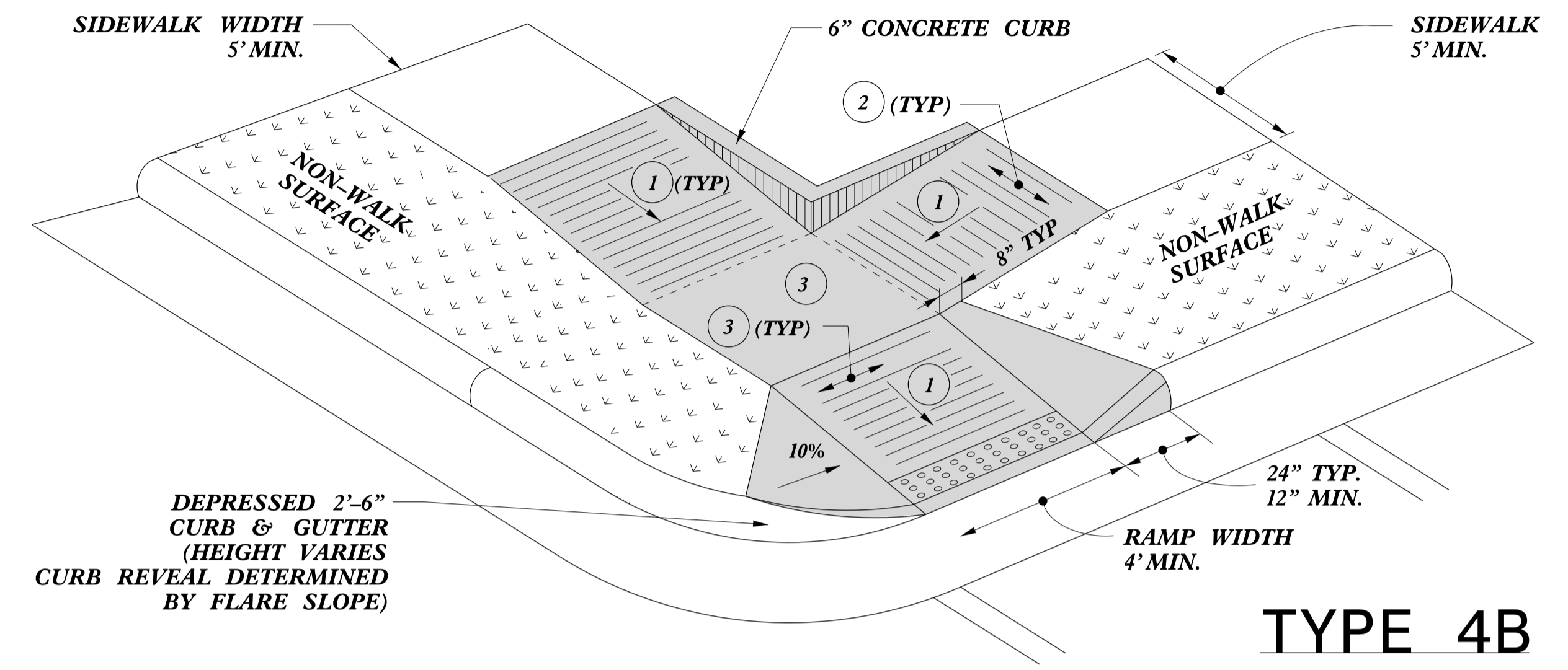

TYPE 4B

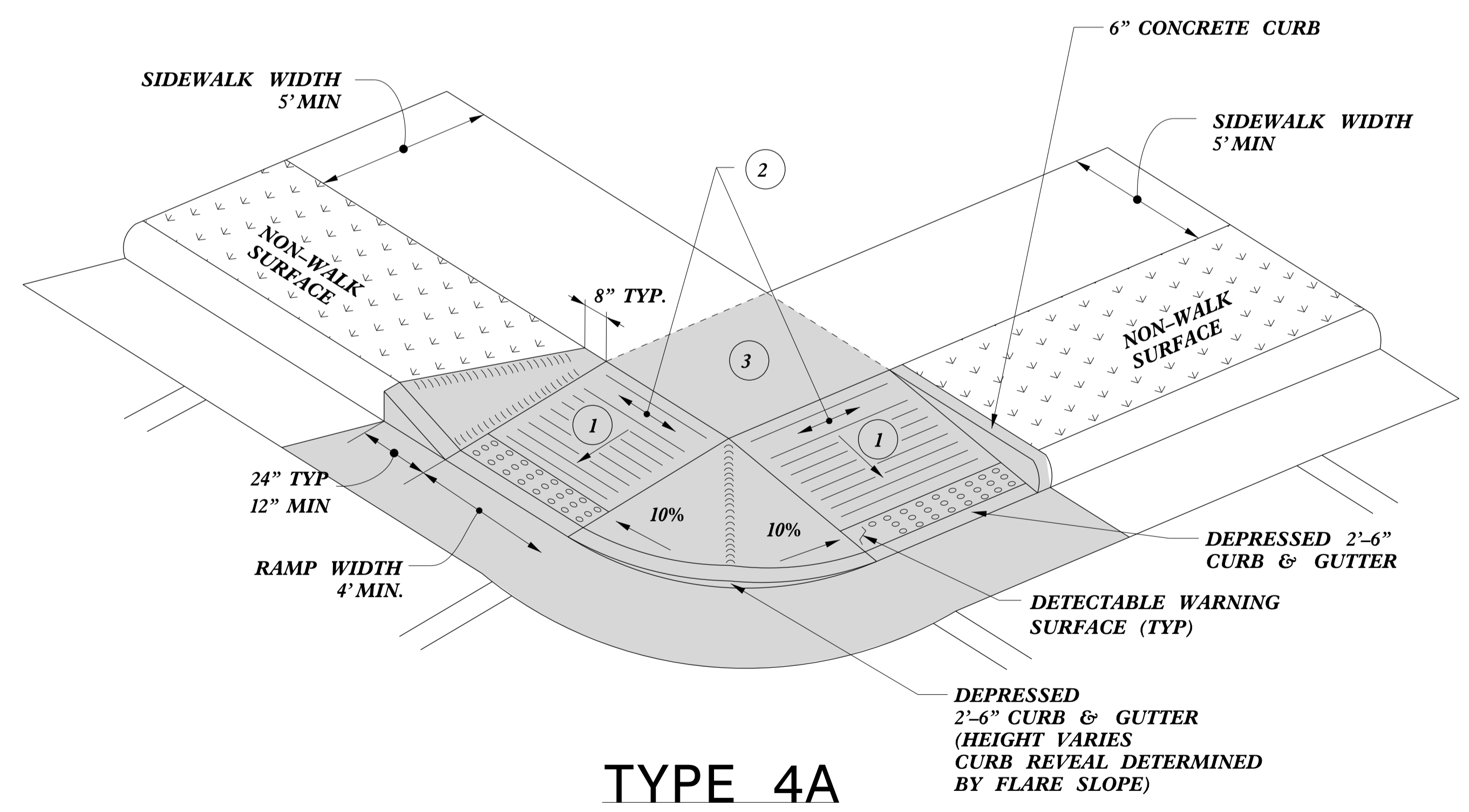

TYPE 4A

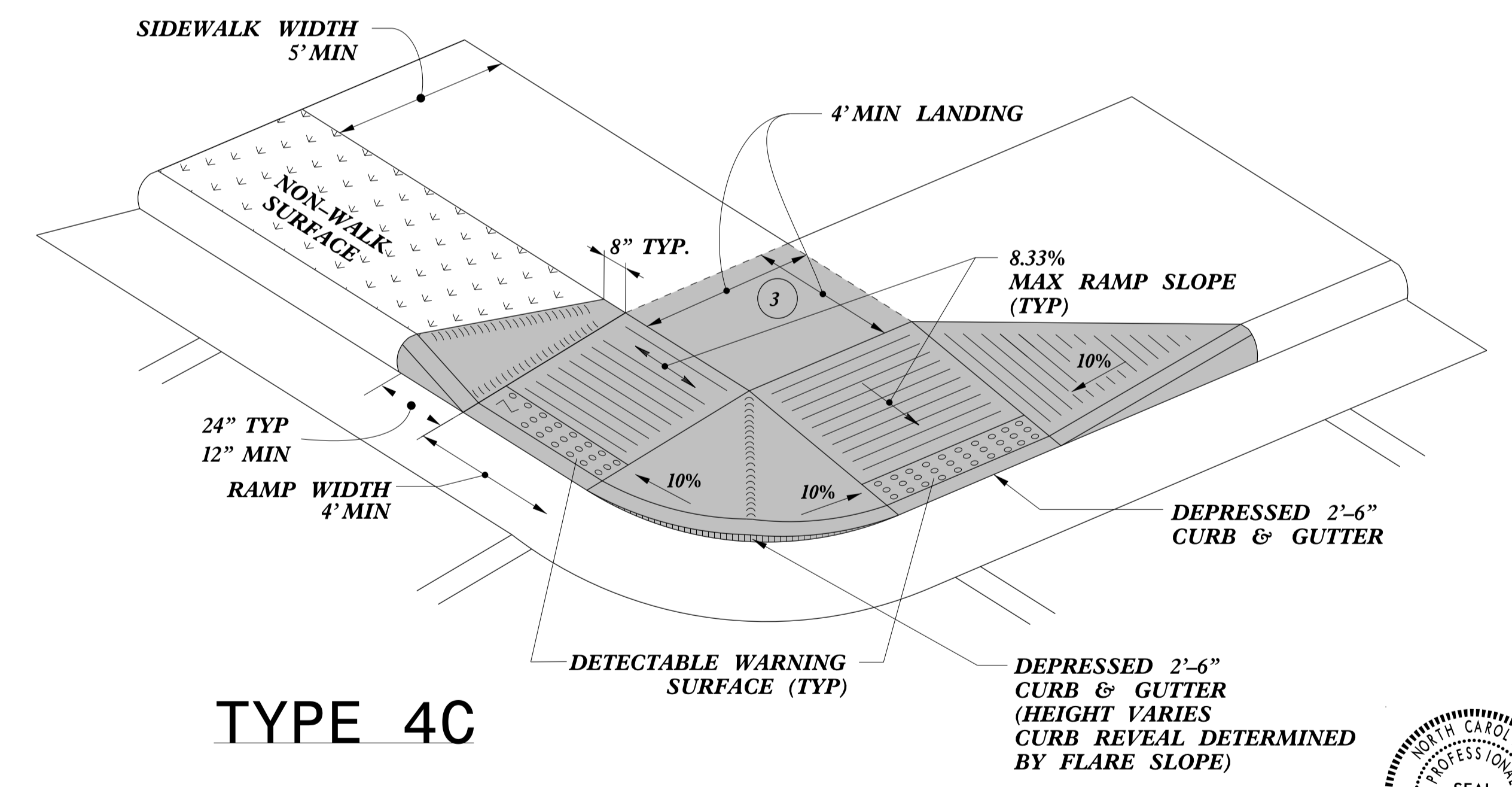

TYPE 4C

- 1 8.33% (12:1) MAX RAMP SLOPE
- 2 CROSS SLOPE: 2.00%
- 3 CURB RAMPS REQUIRE A (4'-0") MINIMUM LANDING WITH A MAXIMUM CROSS SLOPE AND LONGITUDINAL SLOPE OF 2.00% WHERE PEDESTRIANS PERFORM TURNING MANEUVERS. SLOPE TO DRAIN TO CURB.

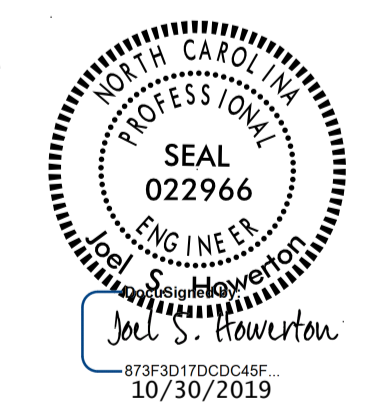

**CONTRACT STANDARDS
AND DEVELOPMENT UNIT**
Office 919-707-6950 FAX 919-250-4119

CURB RAMPS

ORIGINAL BY: J.S. HOWERTON DATE: 7/7/11
 MODIFIED BY: DATE:
 CHECKED BY: DATE:
 FILE SPEC: stds/2012CurbRamp/CurbRampDetails.dgn

5/14/99 J:\COURT\PROJECTS\2012\848.05\848.05.dwg

PAY LIMITS FOR 1 OR 2 CURB RAMPS
(CALCULATE BASED ON NUMBER OF SETS
OF TRUNCATED DOMES)

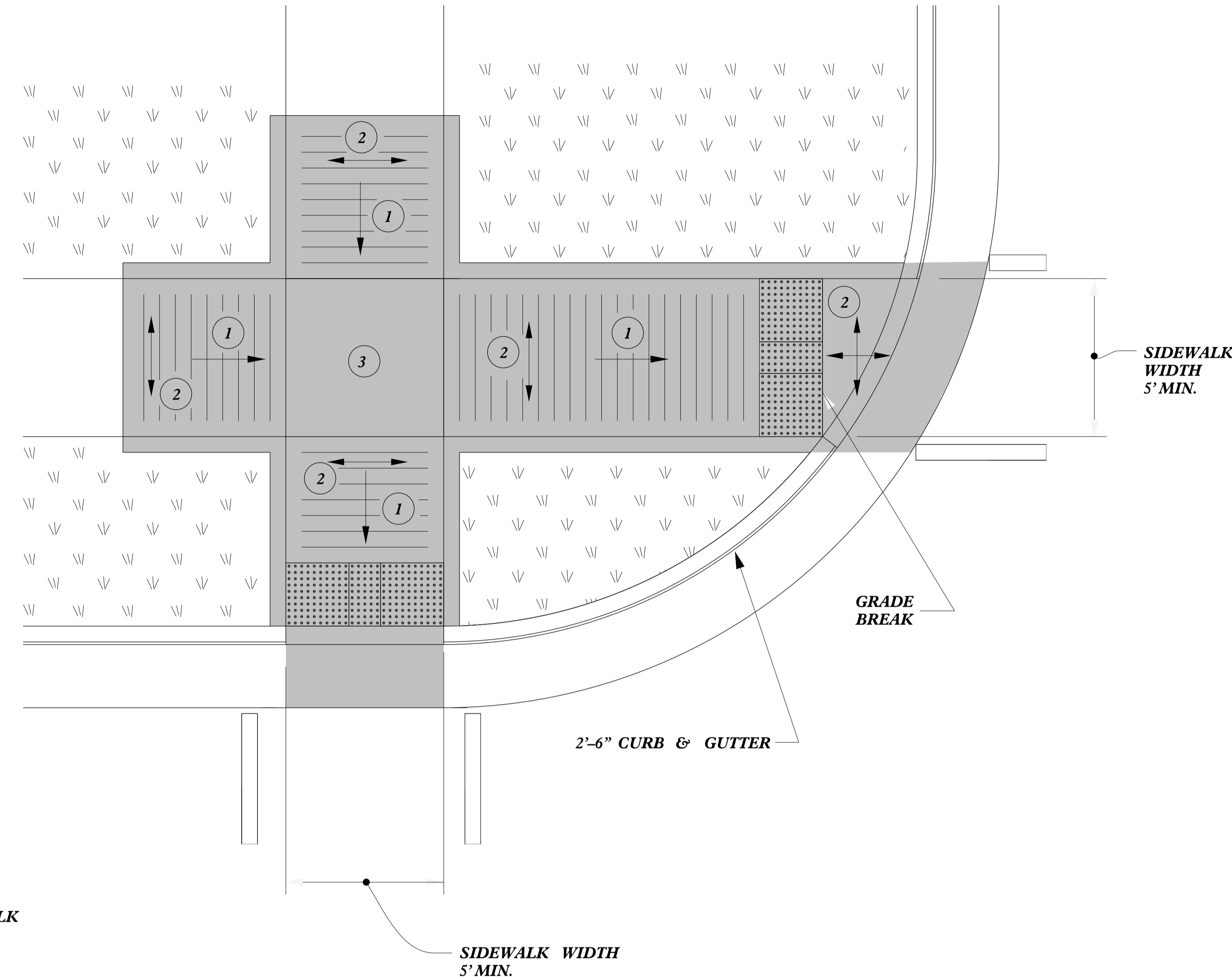

TYPE 5A

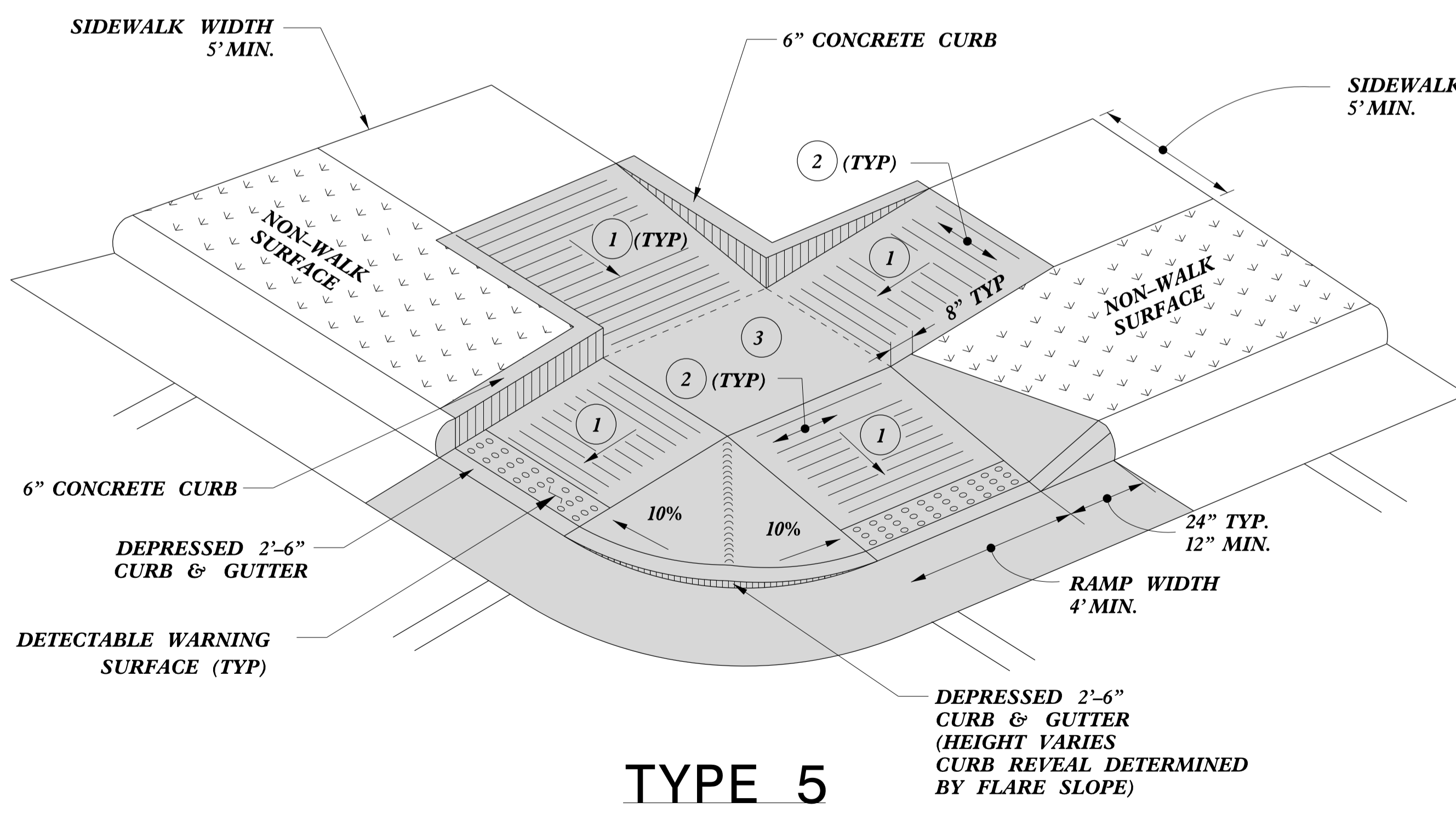

TYPE 5

- 1 8.33% (12:1) MAX RAMP SLOPE
- 2 CROSS SLOPE: 2.00%
- 3 CURB RAMPS REQUIRE A (4'-0") MINIMUM LANDING WITH A MAXIMUM CROSS SLOPE AND LONGITUDINAL SLOPE OF 2.00% WHERE PEDESTRIANS PERFORM TURNING MANEUVERS. SLOPE TO DRAIN TO CURB.

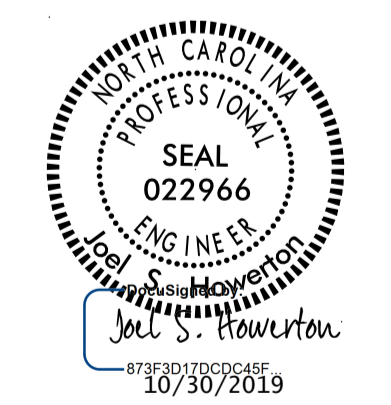

**CONTRACT STANDARDS
AND DEVELOPMENT UNIT**
Office 919-707-6950 FAX 919-250-4119

CURB RAMPS

ORIGINAL BY: J.S. HOWERTON DATE: 7/7/11
 MODIFIED BY: _____ DATE: _____
 CHECKED BY: _____ DATE: _____
 FILE SPEC: :stds/2012CurbRamp/CurbRampDetails.dgn

REFER TO ROADWAY STANDARD DRAWING NUMBER 848.05 SHEET 3 OF 3 FOR ALL RAMP NOTES

5/14/99
 TIME\$\$\$\$
 C:\P\PROJECTS\2012\848.05\848.05.dwg
 USER: JSHWERTON
 PLOT DATE: 10/30/2019

5/14/99

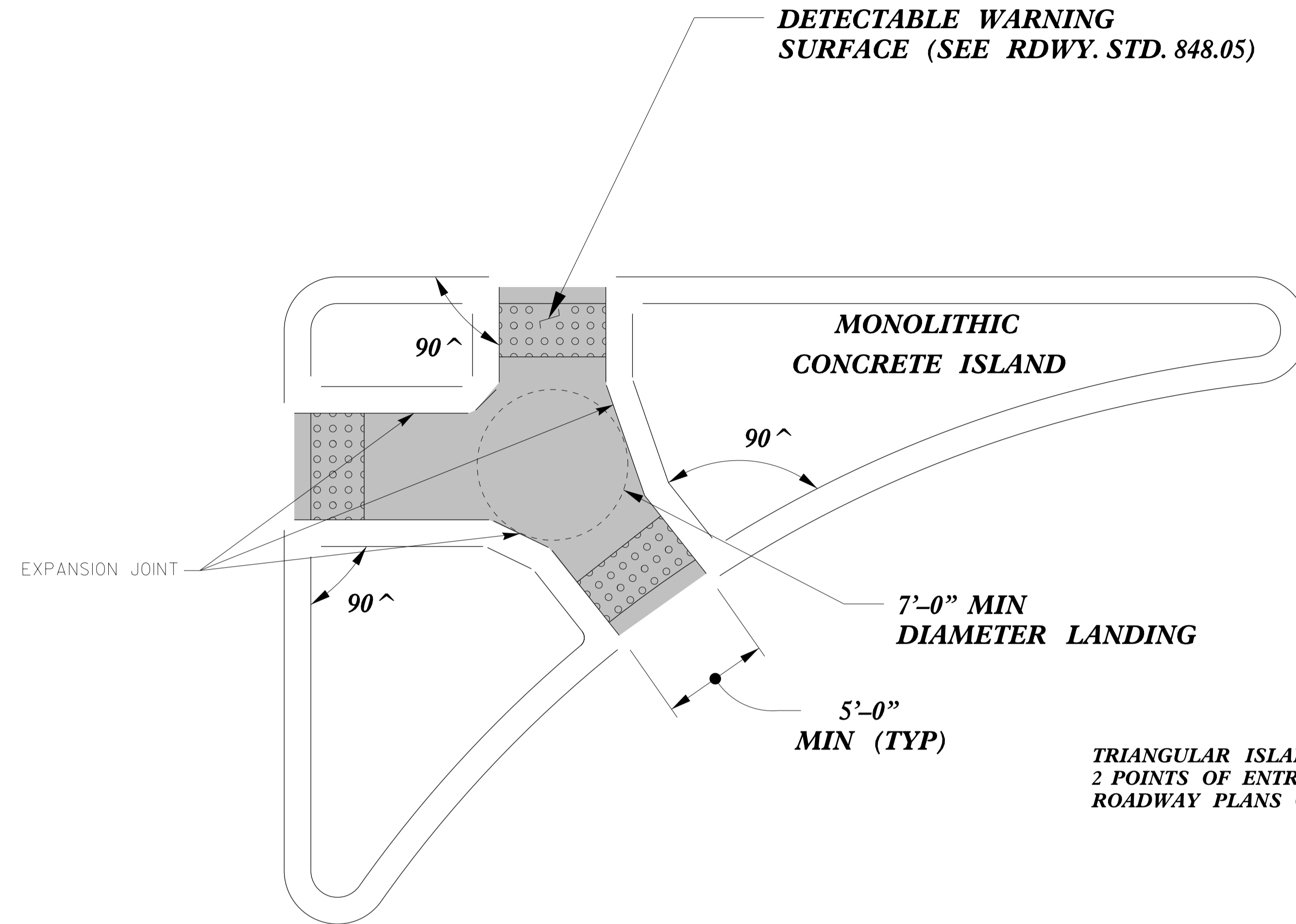

PAY LIMITS FOR 2 OR 3 CURB RAMPS
(CALCULATE BASED ON NUMBER OF SETS OF TRUNCATED DOMES)

TRIANGULAR ISLANDS MAY BE CONSTRUCTED WITH ONLY 2 POINTS OF ENTRY AND EXIT AS SHOWN IN THE ROADWAY PLANS OR AS DIRECTED BY THE ENGINEER.

TRIANGULAR ISLAND WITH CUT THROUGH TYPE 6

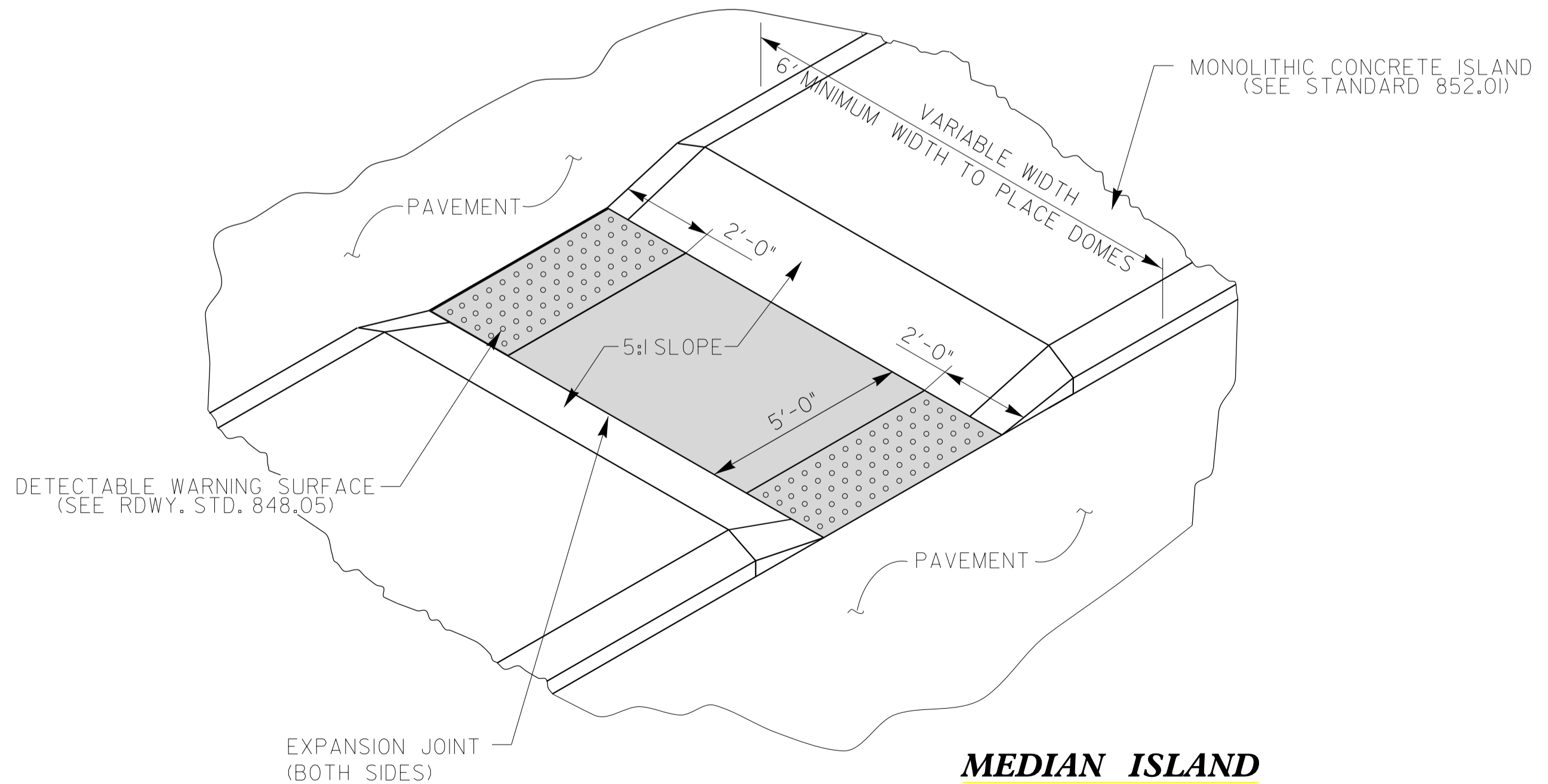

MEDIAN ISLAND WITH CUT THROUGH TYPE 7

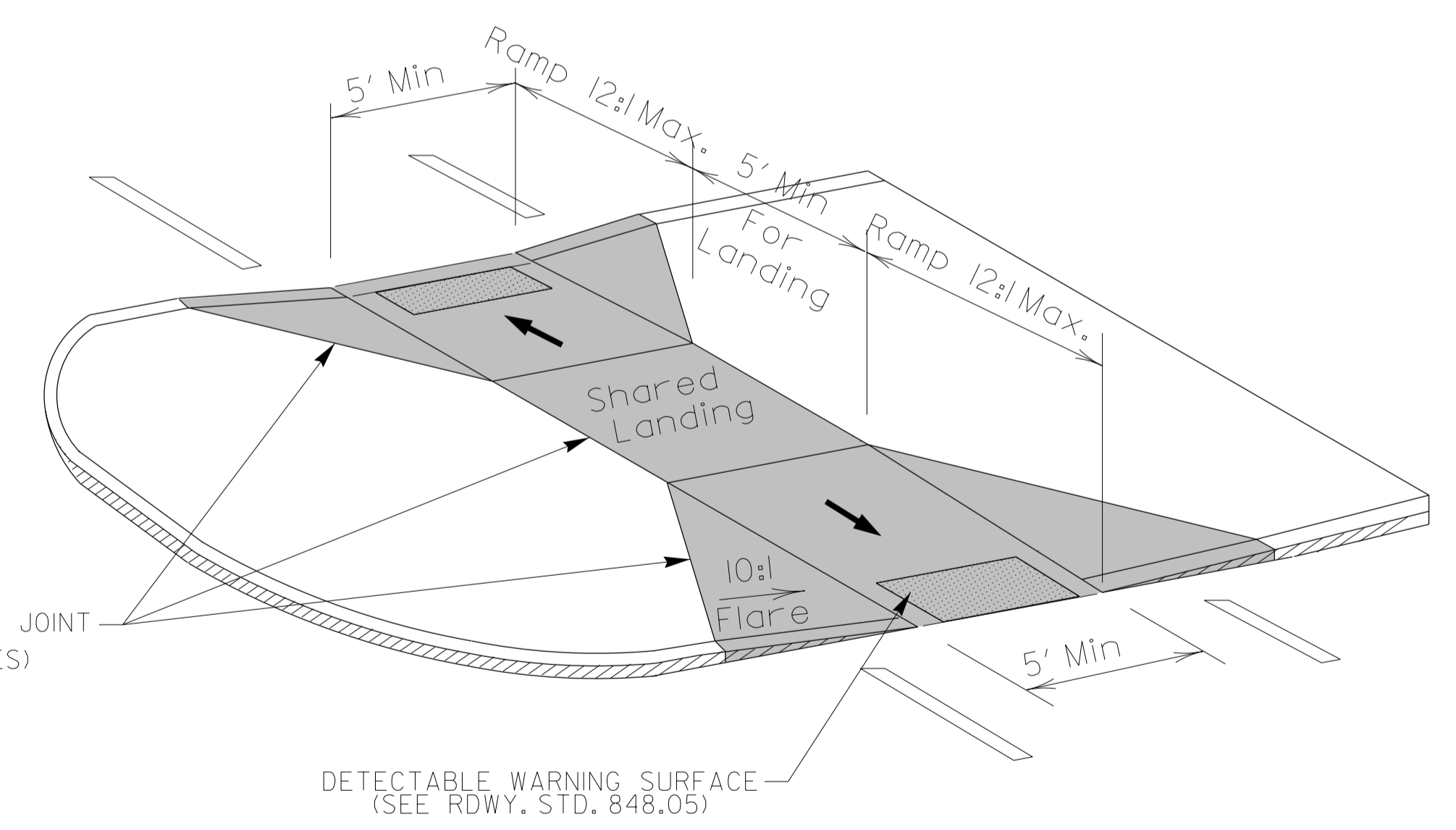

MEDIAN ISLAND CURB RAMPS TYPE 8

\$\$\$\$\$ TIME\$\$\$\$\$ D:\COURT\CONNECTION\$\$\$\$\$ USERNAME\$\$\$\$\$

DOCUMENT NOT CONSIDERED FINAL UNLESS ALL SIGNATURES COMPLETED

CONTRACT STANDARDS AND DEVELOPMENT UNIT
Office 919-707-6950 FAX 919-250-4119

CURB RAMPS
Median or Turn Lane Islands

ORIGINAL BY: J.S. HOWERTON DATE: 7/7/11
 MODIFIED BY: _____ DATE: _____
 CHECKED BY: _____ DATE: _____
 FILE SPEC: .stds/2012CurbRamp/CurbRampDetails.dgn

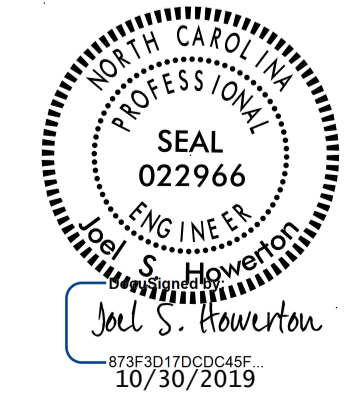

SIGNING FOR RESURFACING PROJECTS

LEGEND
 ┆ STATIONARY SIGN
 ← DIRECTION OF TRAFFIC FLOW

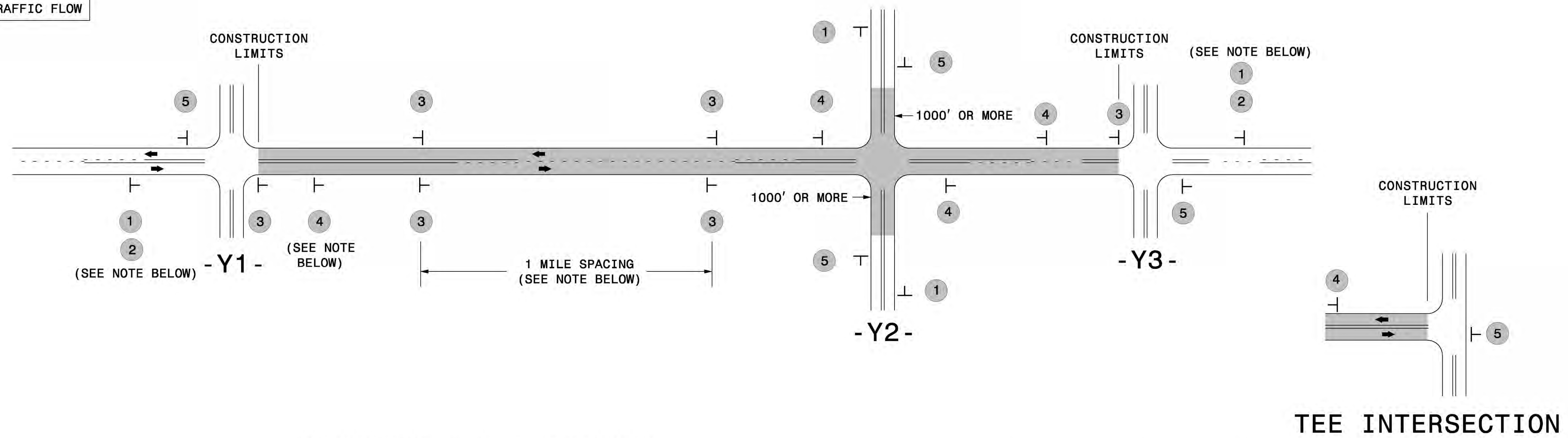

MAINLINE (-L-) SIGNING

-Y- LINE SIGNING

SIGNING NOTES AND PLACEMENT PER DIRECTION	1	 W20-1 48" X 48"	PLACE 1000' PRIOR TO BEGINNING OF CONSTRUCTION LIMITS. ONLY USED ON -Y- LINES IF RESURFACING LIMITS EXTEND 1000' ALONG -Y- LINE.	<p>NO REQUIRED STATIONARY SIGNING FOR THE FOLLOWING -Y- LINE CONDITIONS:</p> <ol style="list-style-type: none"> 1) LESS THAN 1000' OF RESURFACING ALONG -Y- LINE 2) SUBDIVISION ROADS 3) DEAD END ROADS <p>WHEN PAVING/CONSTRUCTION ACTIVITIES PROCEED ACROSS AN UNSIGNED -Y- LINE, PORTABLE ADVANCE WARNING SIGNS SHALL BE USED ALONG THE -Y- LINE AS SHOWN BELOW. REMOVE UPON COMPLETION OF WORK.</p> <div style="display: flex; justify-content: space-around;"> <div style="text-align: center;"> W20-1 48" X 48" </div> <div style="text-align: center;"> W20-7 A 48" X 48" </div> </div> <p>PLACED 500' IN ADVANCE OF FLAGGER.</p> <p>PLACED 250' IN ADVANCE OF FLAGGER.</p>
	2	 W7-3aP 24" X 18"	#2 SIGN ONLY USED WHEN CONSTRUCTION LIMITS ARE 2 OR MORE MILES IN LENGTH. ROUND UP TO NEXT WHOLE NUMBER. (NO FRACTIONAL OR DECIMAL NUMBERS)	
	3	 SP 13107 48" X 48"	<ul style="list-style-type: none"> - PLACE INITIALLY AT THE CONSTRUCTION LIMITS AND SPACE 1 MILE APART THEREAFTER. - AT TEE INTERSECTIONS INSTALL INITIALLY 1/2 MILE FROM INTERSECTION AND SPACE 1 MILE APART THEREAFTER. 	
	4	 SP 13106 48" X 48"	<ul style="list-style-type: none"> - THESE ARE FOR -Y- LINES THAT ARE "THROUGH" ROADWAYS. - DEAD END AND SUBDIVISION ROADS ARE NOT "THROUGH" ROADWAYS. - INSTALL 500' +/- FROM EACH -Y- LINE APPROACH AS SHOWN ABOVE. - FOR MULTIPLE -Y- LINES THAT ARE SEPARATED BY 0.25 MILES OR LESS, TREAT AS A SINGLE UNIT AND INSTALL WITHIN 500' OF EACH APPROACH. - A MAXIMUM OF 2 SIGN SETS PER MILE. DO NOT INSTALL WHEN -Y- LINES ARE WITHIN 0.5 MILES FROM "END ROAD WORK" SIGN. - FOR TEE INTERSECTIONS, INSTALL WITHIN 500' +/- OF THE INTERSECTION ALONG -L- LINE. 	
	5	 G20-2 A 48" X 24"	PLACE 500' FOLLOWING THE END OF CONSTRUCTION LIMITS OR AS SHOWN WHEN WORK ENDS AT A 3-WAY TEE INTERSECTION.	

THE ABOVE SIGNS ARE ALL THAT ARE REQUIRED FOR A CONTRACTOR TO BEGIN A RESURFACING CONTRACT. ANY ADDITIONAL SIGNS REQUESTED BY NCDOT DIVISIONS SHALL BE INSTALLED WITHIN 7 BUSINESS DAYS OF THE START OF CONTRACT WORK.

MAPS LESS THAN 2 MILES

FOR RESURFACING MAPS WITH CONSTRUCTION LIMITS LESS THAN 2 MILES IN LENGTH, NO STATIONARY SIGNS ARE REQUIRED. USE PORTABLE "ROAD UNDER CONSTRUCTION" OR "ROAD WORK AHEAD" SIGNS IN LIEU OF STATIONARY ADVANCE WARNINGS SIGNS.

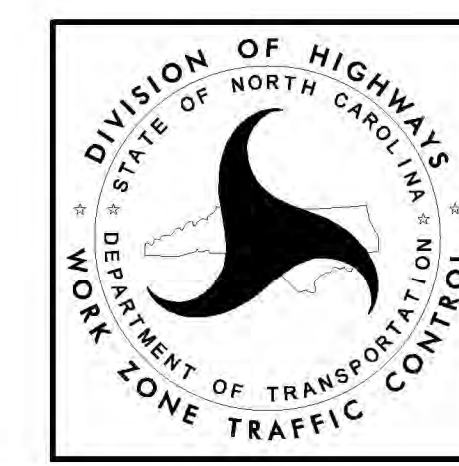

ADVANCE WARNING SIGNS FOR RURAL AND SUBURBAN 2-LANE ROADWAY RESURFACING

5/15/2017 5:11:10 PM \\NCDOT\resurfacing\212W & AST Resurfacing Details\Resurfacing_AdvWarn_212W.dgn User:keads

URBAN / SUBURBAN WORKZONES

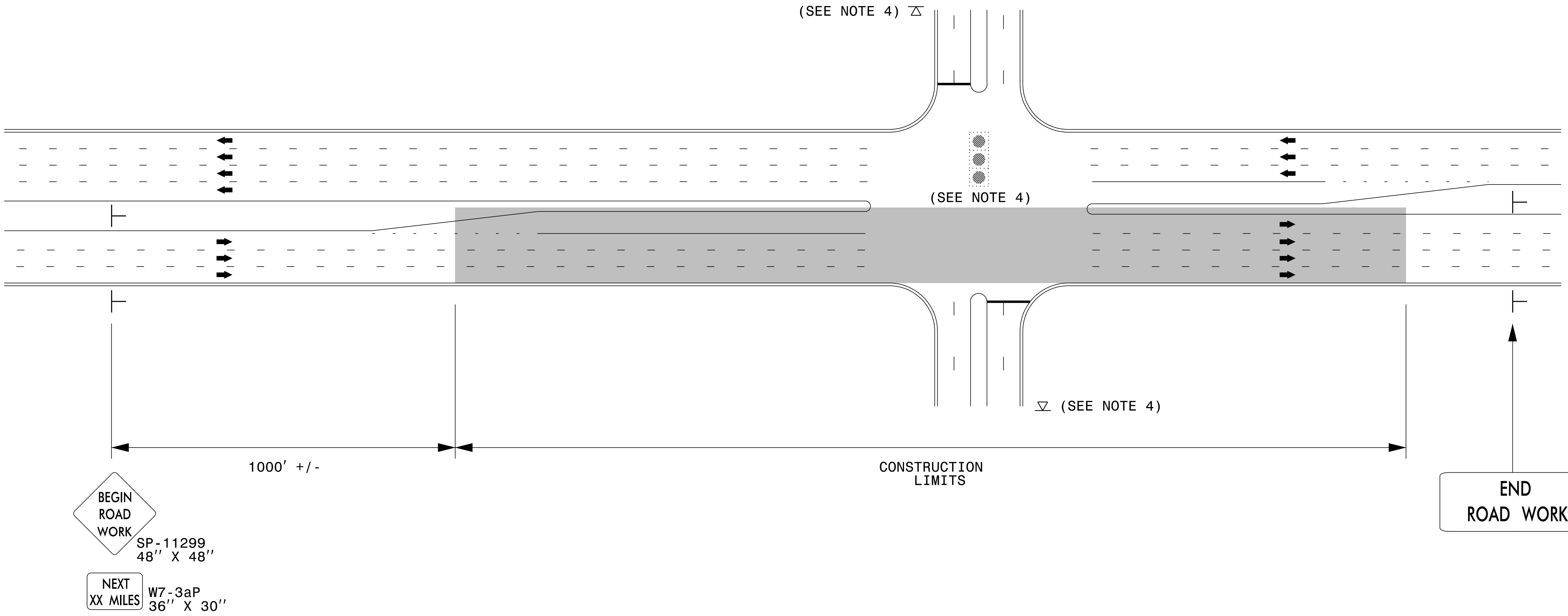

NOTES:

- 1) 48" x 48" SIZED SIGNS (SP- 11299) MAY BE REDUCED TO 36" X 36" ON ROADWAYS WITH SPEED LIMITS OF 40 MPH OR LESS.
- 2) MOUNT SIGNS THAT ARE LARGER THAN 10 SQUARE FEET IN AREA ON TWO OR MORE WOOD OR U-CHANNEL SUPPORTS. PERFORATED SQUARE TUBING SUPPORT SYSTEMS MAY SUPPORT LARGER AREAS ON A SINGLE SUPPORT. FOLLOW MANUFACTURER'S RECOMMENDATIONS. THESE SYSTEMS SHALL BE NCHRP 350 COMPLIANT AND NCDOT APPROVED.
- 3) ADVANCE WARNING SIGNS NOT REQUIRED ON NON-SIGNALIZED SIDE STREETS.
- 4) MAY USE LAW ENFORCEMENT TO CONTROL TRAFFIC AT SIGNALIZED INTERSECTIONS AS DIRECTED BY THE ENGINEER. PROVIDE PORTABLE "ROAD WORK AHEAD" (W20-1) SIGNS 500' IN ADVANCE ALONG BOTH APPROACHES FROM THE SIDE STREETS WHEN PAVING PROCEEDS THROUGH THE INTERSECTION.
- 5) LATERAL CLEARANCE AT ALL SIGN LOCATIONS SHALL BE 2' AS MEASURED FROM THE EDGE OF PAVEMENT OR THE FACE OF THE CURB. WHEN UNABLE TO OBTAIN THE LATERAL CLEARANCE WITHIN THE MEDIAN AREA USE SHOULDER MOUNTS ONLY.
- 6) SIGN MOUNT LOCATIONS SHALL NOT BLOCK SIDEWALKS OR DRIVEWAYS.
- 7) IF STATIONARY GENERAL WARNING SIGNS ARE USED, THEY WILL BE PAID FOR PER SECTION 104 OF THE NCDOT STANDARD SPECIFICATIONS AS EXTRA WORK.
- 8) IF MILLED AREAS ARE NOT PAVED BACK BY THE END OF THE WORK DAY, PORTABLE SIGNS SHALL BE USED TO WARN DRIVERS OF THE PRESENT CONDITIONS. THESE ARE TO INCLUDE, BUT NOT LIMITED TO "ROUGH ROAD" W8-8, "UNEVEN LANES" W8-11, "GROOVED PAVEMENT" W8-15 w/MOTORCYCLE PLAQUE MOUNTED BELOW. THESE ARE TO BE DOUBLE INDICATED ON MULTI-LANE ROADWAYS WITH SPEED LIMITS 45 MPH AND GREATER WHERE LATERAL CLEARANCE CAN BE OBTAINED WITHIN THE MEDIAN AREAS. THESE PORTABLE SIGNS ARE INCIDENTAL TO THE OTHER ITEMS OF WORK INCLUDED IN THE TEMPORARY TRAFFIC CONTROL (LUMP SUM) PAY ITEM.

LEGEND

┆ STATIONARY SIGN

➔ DIRECTION OF TRAFFIC FLOW

END ROAD WORK
G20-2 A
48" X 24"

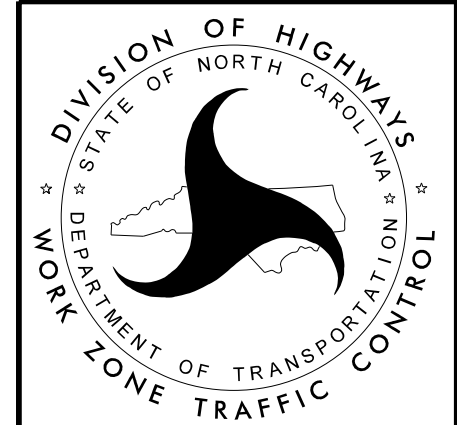

RESURFACING ADVANCE WARNING SIGNS FOR URBAN / SUBURBAN FACILITIES

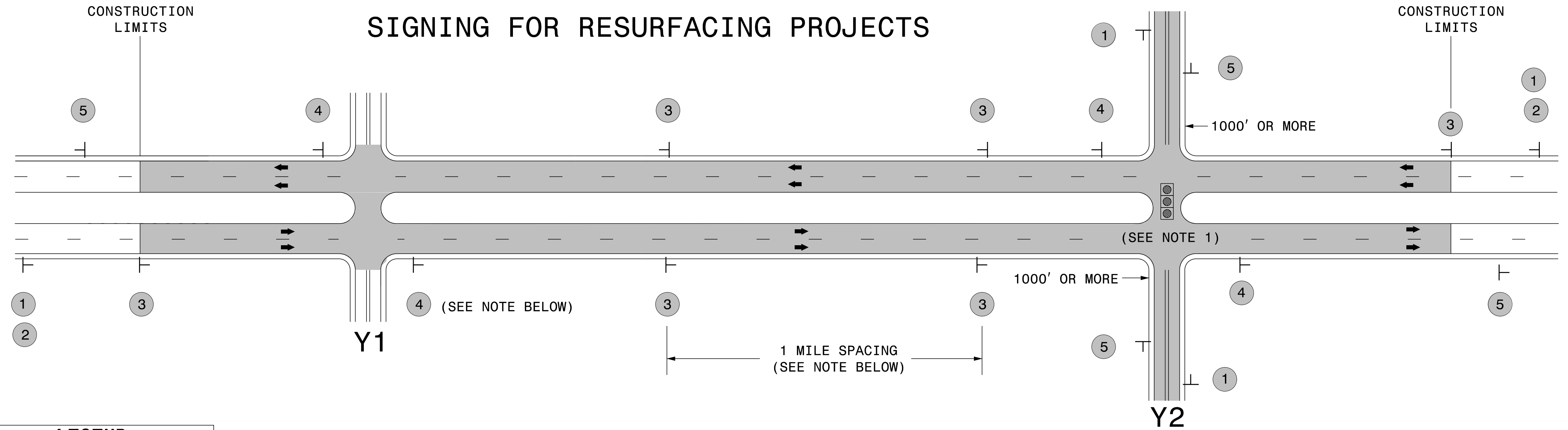

LEGEND
 ┆ STATIONARY SIGN
 ← DIRECTION OF TRAFFIC FLOW

MAINLINE (-L-) SIGNING

-Y- LINE SIGNING

SIGNING NOTES AND PLACEMENT PER DIRECTION	 	<p>PLACE 1000' PRIOR TO BEGINNING OF CONSTRUCTION LIMITS. ONLY USED ON -Y- LINES IF RESURFACING LIMITS EXTEND 1000' ALONG -Y- LINE.</p> <p>#2 SIGN ONLY USED WHEN RESURFACING LIMITS ARE 2 OR MORE MILES IN LENGTH. ROUND UP TO NEXT WHOLE NUMBER. (NO FRACTIONAL OR DECIMAL NUMBERS)</p>	<p>NO REQUIRED STATIONARY SIGNING FOR THE FOLLOWING -Y- LINE CONDITIONS:</p> <ol style="list-style-type: none"> 1) LESS THAN 1000' OF RESURFACING ALONG -Y- LINE 2) SUBDIVISION ROADS 3) DEAD END ROADS <p>WHEN PAVING/CONSTRUCTION ACTIVITIES PROCEED ACROSS AN UNSIGNED -Y- LINE, ADVANCE WARNING PORTABLE SIGNS SHALL BE USED ALONG THE -Y- LINE AS SHOWN BELOW. REMOVE UPON COMPLETION OF WORK.</p> <div style="display: flex; justify-content: space-around; align-items: center;"> <div style="text-align: center;"> <small>W20-1 48" X 48"</small> </div> <div style="text-align: center;"> <small>W20-7 A 48" X 48"</small> </div> </div> <p>PLACED 500' IN ADVANCE OF FLAGGER. PLACED 250' IN ADVANCE OF FLAGGER.</p> <p>NOTES:</p> <ol style="list-style-type: none"> 1) MAY USE LAW ENFORCEMENT TO CONTROL TRAFFIC AT SIGNALIZED INTERSECTIONS AS DIRECTED BY THE ENGINEER. PROVIDE PORTABLE "ROAD WORK AHEAD" (W20-1) SIGNS 500' IN ADVANCE ALONG BOTH APPROACHES FROM THE SIDE STREETS WHEN PAVING PROCEEDS THROUGH THE INTERSECTION.
		<p>PLACE INITIALLY AT THE CONSTRUCTION LIMITS AND SPACED 1 MILE APART THEREAFTER. IF NO -Y- LINES EXIST, PLACE 2ND SET 1/2 MILE FROM THE CONSTRUCTION LIMITS AND THEN SPACE 1 MILE THEREAFTER.</p>	
		<p>THESE ARE FOR -Y- LINES THAT ARE "THROUGH" ROADWAYS. DEAD END AND SUBDIVISION ROADS ARE NOT "THROUGH" ROADWAYS. INSTALL 500' +/- FROM EACH -Y- LINE APPROACH AS SHOWN ABOVE. FOR MULTIPLE -Y- LINES THAT ARE SEPARATED BY 0.25 MILES OR LESS, TREAT AS A SINGLE UNIT AND INSTALL WITHIN 500' OF EACH APPROACH. A MAXIMUM OF 2 SIGN SETS PER MILE. DO NOT INSTALL WHEN -Y- LINES ARE WITHIN 0.5 MILES FROM "END ROAD WORK" SIGN.</p>	
		<p>PLACE 500' FOLLOWING THE END OF CONSTRUCTION LIMITS.</p>	

3/23/2015
 C:\Users\rmgarrrett\Downloads\Resurfacing_AdvWarn_Ltr-Su_Shldr.dgn
 User:rmgarrrett

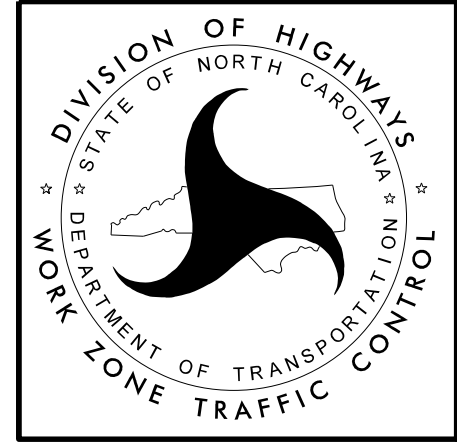

**RESURFACING
 ADVANCE WARNING SIGNS
 FOR RURAL AND SUBURBAN
 MULTI-LANE ROADWAYS
 W/ SHOULDER SECTIONS**

- NOTES:
- 1) DETAIL DOES NOT APPLY TO OGAFc AND ULTRA-THIN BONDED WEARING COURSE.
 - 2) BACKFILL SHOULDER WITH APPROVED MATERIAL.
 - 3) THE SHOULDER WEDGE DEVICE MAY BE DISENGAGED AT PAVED DRIVEWAYS AND SIDE STREETS.

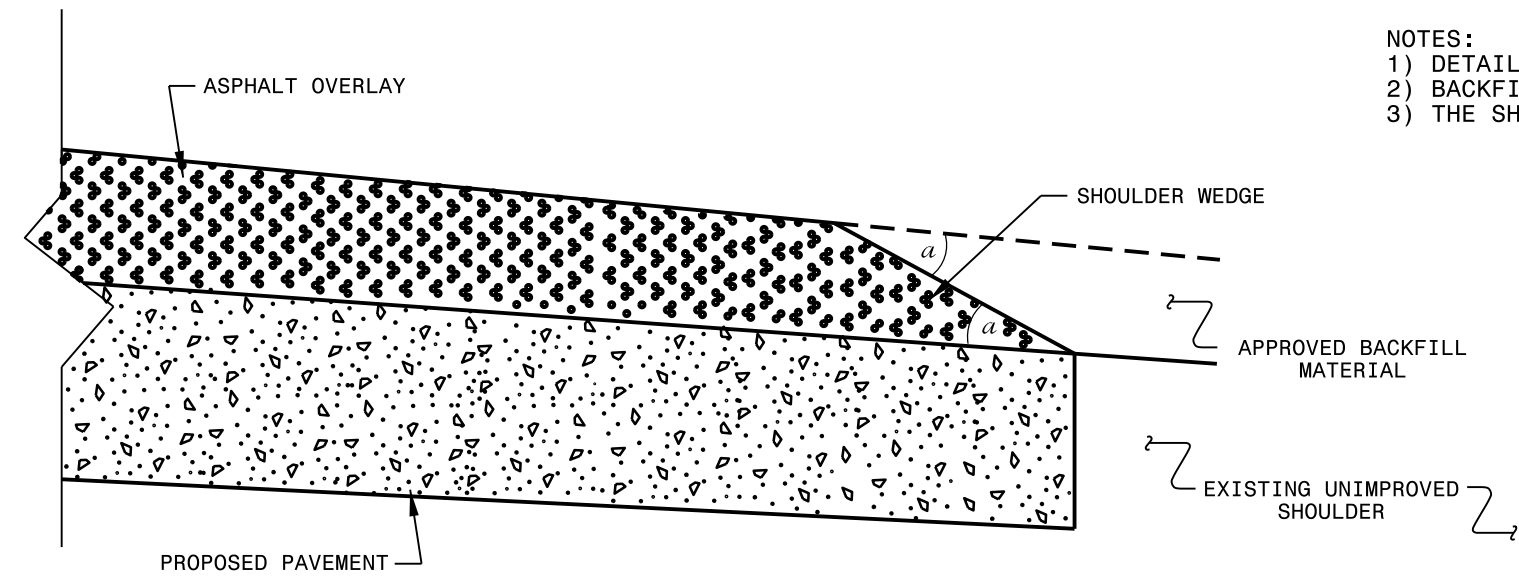

SHOULDER WEDGE DETAIL
 (Resurfacing Projects w/ Widening or
 with Existing Paved Shoulder having no dropoffs)

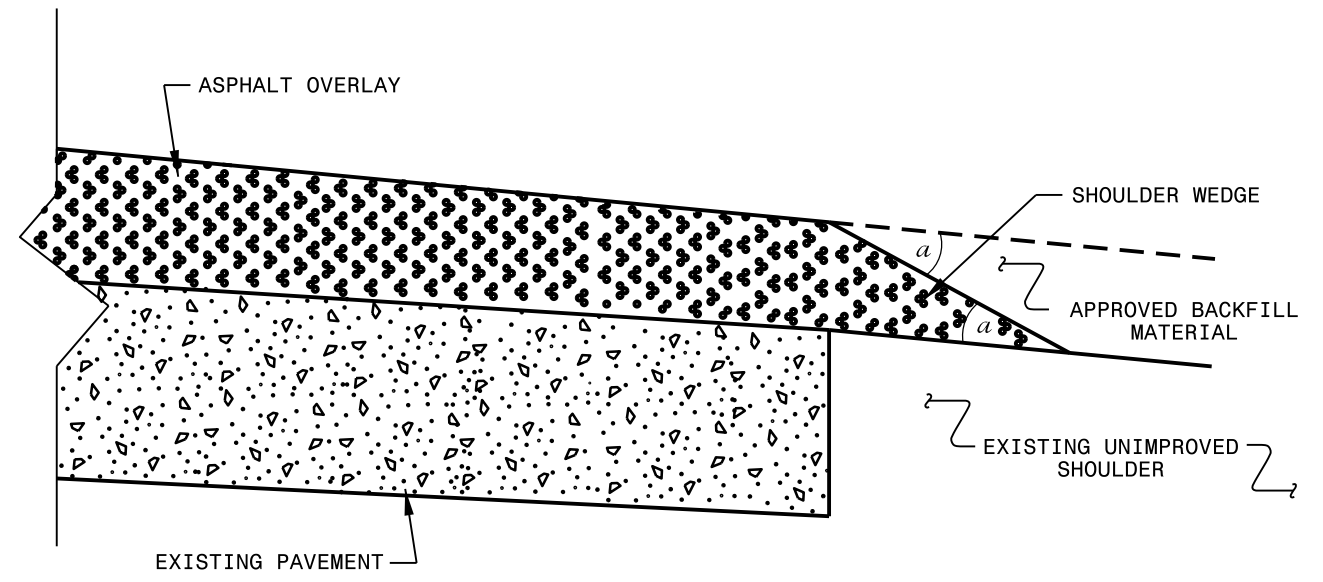

SHOULDER WEDGE DETAIL
 (Resurfacing Projects w/ NO Widening)

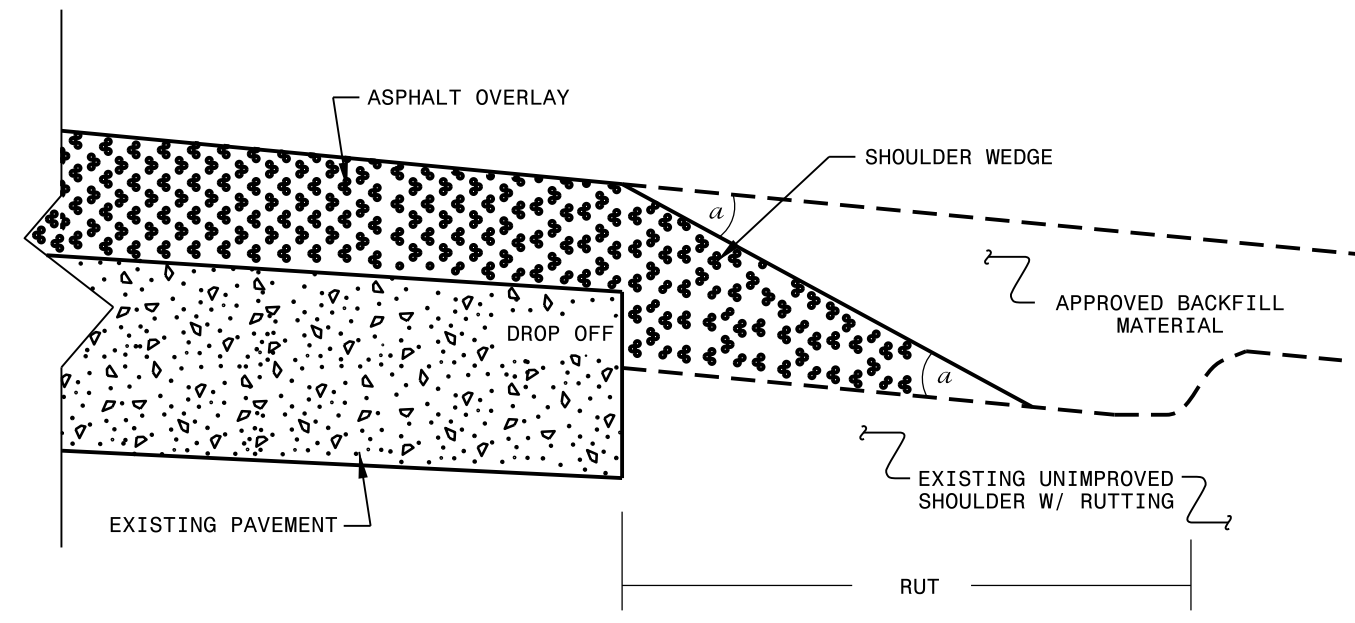

SHOULDER WEDGE DETAIL
 (Resurfacing Adjacent to
 Rutted Shoulder)

- SHOULDER WEDGE ANGLE = 30°

CONTRACT STANDARDS AND DEVELOPMENT UNIT			
Office 919-707-6950		FAX 919-250-4119	
SHOULDER WEDGE DETAILS			
ORIGINAL BY: T.SPELL	DATE: 7-19-11		
MODIFIED BY:	DATE: 10/16/12		
CHECKED BY:	DATE:		
FILE SPEC.: susr/details/stand/shoulderwedgedetail.dgn			

SYSTEMS DESIGN
 USER NAME

